

# WALLS

WALLS, PILLARS & PLANTERS



Borealis	P. 162	Prescott	P. 203
Brandon	P. 165	Raffinato	P. 211
Fascia Wall Collection	P. 176	Röcka	P. 222
Fascia Iconic	P. 177	Sandstone	P. 225
Fascia Rosemont	P. 178	Semma	P. 227
G-Force	P. 183	Skyscraper	P. 233
Graphix	P. 188	Systema	P. 239
Mini-Creta Architectural	P. 192	Travertina Raw	P. 241

## PHYSICAL AND GEOMETRICAL CHARACTERISTICS

CHARACTERISTICS		ASTM C 1372	TECHO-BLOC
Compressive strength		3 000 psi [21 MPa] min.	5 050 psi [35 MPa] min.
Water absorption		13 lb/ft <sup>3</sup> [208 kg/m <sup>3</sup> ] max	9 lb/ft <sup>3</sup> [144 kg/m <sup>3</sup> ] max.
Freeze-thaw durability		Mass loss (max.): 1% at 100 cycles, or Mass loss (max.): 1.5% at 150 cycles	Mass loss (max.): 1% at 100 cycles, or Mass loss (max.): 1.5% at 150 cycles
Dimension tolerance <sup>1</sup>	length	± 1/8" [3.2 mm]	± 1/8" [3.2 mm]
	width	± 1/8" [3.2 mm]	± 1/8" [3.2 mm]
	height	± 1/8" [3.2 mm]	± 1/8" [3.2 mm]

Notes : 1. The dimension tolerance is not applicable to split facings or other architectural finish.

2. The dimensional tolerance for Stonedge wet cast retaining wall units is: ± 3/16" (5 mm) for height and ± 1/2" (13 mm) for length and width.

3. During the installation, the level between adjacent wall units will vary (usually more than for a dry cast wall unit) in order to obtain a more realistic appearance of a natural stone wall. Stonedge collection of wet cast wall units include, but are not limited to, the following: Borealis, Prescott, Röcka and Travertina Raw wall units.

# APPLICATION CHART

PRODUCT	Depth (Nominal)		Batter	Connector Type	Alignment		Retaining Walls						Freestanding Walls	Pillars	Steps	Outdoor Fire Features		
	mm	in.			Straight Wall	Curved Wall	Typical Height Range <sup>(3)</sup>			Gravity		Geogrid Reinforced				PerVIOUS Concrete Backfill	Fire Pit	Grill Island
							Landscaping up to 1.5-4 ft	Miscellaneous up to 8-10 ft	Heavy Duty 10 ft and above	Single Depth	Multi-Depth							
BOREALIS	203	8	0° <sup>(1)(2)</sup>	-	X		X			X			X			X <sup>(6)</sup>	X <sup>(6)</sup>	
BRANDON	250	9 13/16	0°; 4.4° <sup>(1)</sup>	HDPE Vertical Key (Short)	X	X		X		X	X	X	X	X <sup>(4)</sup>	X	X <sup>(6)</sup>	X <sup>(6)</sup>	
FASCIA <sup>(8)</sup>	263	10 3/8	0°; 5.3° <sup>(1)</sup>	HDPE Horizontal Key & Front Lip	X		X		X	X	X	X	X	X	X		X <sup>(6)</sup>	
G-FORCE	290	11 7/8	3.9°	HDPE Vertical Key (Long)	X	X			X	X	X	X		X <sup>(4)</sup>	X	X <sup>(6)</sup>	X <sup>(6)</sup>	
GRAPHIX	205 - 280	8 1/8 - 11	Variable	HDPE Horizontal Key	X			X	X	X	X	X	X	X	X		X <sup>(6)</sup>	
MINI-CRETA	250	9 13/16	0°; 5.3° <sup>(1)</sup>	HDPE Horizontal Key	X	X		X	X	X	X	X	X	X <sup>(4)</sup>	X	X <sup>(6)</sup>	X <sup>(6)</sup>	
PRESCOTT	250	9 13/16	0°; 4.5° <sup>(1)</sup>	HDPE Vertical Key (Short)	X	X	X		X	X	X		X	X <sup>(4)</sup>	X	X <sup>(6)</sup>	X <sup>(6)</sup>	
RAFFINATO	249	9 13/16	0°; 4.4° <sup>(1)</sup>	HDPE Vertical Key (Short)	X	X		X	X	X	X	X	X	X <sup>(4)</sup>	X	X <sup>(6)</sup>	X <sup>(6)</sup>	
RÖCKA	203	8	0° <sup>(1)(2)</sup>	-	X		X		X				X			X <sup>(6)</sup>	X <sup>(6)</sup>	
SEMMA	279	11	0°; 7.6° <sup>(1)</sup>	HDPE Horizontal Key	X	X			X	X	X	X	X	X <sup>(4)</sup>	X	X <sup>(6)</sup>	X <sup>(6)</sup>	
SKYSCRAPER <sup>(9)</sup>	590 - 1220	23 1/4 - 48 1/8	0.8°; 12.7°	Precast Concrete Key	X	X			X	X								
SYSTEMA	254	10	0°; 4.4° <sup>(1)</sup>	HDPE Horizontal Key	X		X <sup>(10)</sup>		X	X	X	X	X	X	X			
TRAVERTINA RAW	202	7 15/16	0°; 5.2° <sup>(1)</sup>	HDPE Vertical Key (Short)	X		X		X				X	X <sup>(4)</sup>	X		X <sup>(6)</sup>	

<sup>(1)</sup> For 0° degree (vertical) batter retaining walls, it is recommended a slight positive batter achieved by tilting the top surface of the leveling pad from front to back. This will accommodate forward rotation of the wall during or after installation. This can be achieved with linear wall only (no curves, no corners).

<sup>(2)</sup> Alternatively to tilting the leveling pad, an offset of 1/4" (6 mm) min. per row could be used instead.

<sup>(3)</sup> These typical height ranges may require geogrid. Contact our Technical Support for assistance.

<sup>(4)</sup> Available Corner/Pillar units, sold separately.

<sup>(5)</sup> Installation drawing available.

<sup>(6)</sup> Not pre-assembled kits available.

<sup>(7)</sup> Pre-assembled kits available.

<sup>(8)</sup> Fascia Wall product includes Iconic and Rosemont Fascia wall collections. The nominal depth of the fascia assembly consists of a single-sided structural block combined with a fascia panel or corner unit.

<sup>(9)</sup> Mechanical installation required.

<sup>(10)</sup> Systema walls are recommended for geogrid-reinforced applications up to 6 ft (1.8 m); taller reinforced walls (up to 10 ft [3.0 m]) may be feasible when designed by a qualified engineer based on site-specific conditions and project requirements.

# INSTALLATION GUIDE

## GRAVITY RETAINING WALL CHARACTERISTICS - RESIDENTIAL

The chart below provides general information for residential garden walls based on optimal conditions (see Note 2 below). Contact our Technical Service department if your project requires a higher wall, conditions are not optimal or for commercial applications.

WALL PRODUCT	MAXIMUM TOTAL HEIGHT (INCLUDING EMBEDMENT) WITHOUT SURCHARGE OR SLOPE												MINIMUM DRAINAGE COLUMN WIDTH		MINIMUM RADIUS	
	INCLINED						VERTICAL									
	ANGLE	SETBACK		HEIGHT		ANGLE	SETBACK		HEIGHT							
	(°)	mm	in.	ROWS	mm	in.	(°)	mm	in.	ROWS	mm	in.				
BOREALIS	-	-	-	-	-	-	0.0	0.0	0	3	457	18	400	16	-	-
BRANDON 90 mm	4.4	7.0	¼	8	720	28	0.0	0.0	0	6	540	21	350	14	2.3	7'-6"
BRANDON 180 mm	4.4	14.0	⅜	4	720	28	0.0	0.0	0	3	540	21	350	14	2.3	7'-6"
FASCIA <sup>(4)</sup>	5.3	14.0	⅜	5	750	30	0.0	0.0	0	4	600	24	350	14	-	-
GRAPHIX	VARIABLE			8	600	24	-	-	-	-	-	-	350	14	-	-
G FORCE	3.9	14.0	⅜	4	813	32	-	-	-	-	-	-	300	12	3.0	9'-10"
MINI-CRETA 3"	5.3	7.0	¼	10	750	30	0.0	0.0	0	8	600	24	350	14	2.1	7'-0"
MINI-CRETA 6"	5.3	14.0	⅜	5	750	30	0.0	0.0	0	4	600	24	350	14	2.1	7'-0"
PRESCOTT 2.25"	4.5	4.5	⅜	14	800	32	0.0	0.0	0	12	686	27	350	14	1.6	5'-2"
PRESCOTT 4.5"	4.5	9.0	⅜	7	800	32	0.0	0.0	0	6	686	27	350	14	1.6	5'-2"
RAFFINATO 90 mm	4.4	7.0	¼	8	720	28	0.0	0.0	0	6	540	21	350	14	2.6	8'-6"
RAFFINATO 180 mm	4.4	14.0	⅜	4	720	28	0.0	0.0	0	3	540	21	350	14	2.6	8'-6"
RÖCKA	-	-	-	-	-	-	0.0	0.0	0	3	457	18	400	16	-	-
SEMMA	7.6	20.0	13/16	6	900	35	0.0	0.0	0	4	600	24	330	13	2.1	7'-0"
SKYSCRAPER	12.7	68.5	2 11/16	SEE SKYSCRAPER DESIGN CHART			0.8	4.5	3/16	SEE SKYSCRAPER DESIGN CHART			300	12	INSIDE CURVE 5.5   18'-0" OUTSIDE CURVE 11.0   36'-1"	
SYSTEMA	4.4	14	⅜	3	540	21	0.0	0.0	0	3	540	21	350	14	-	-
TRAVERTINA RAW	5.2	14.0	⅜	5	762	30	0.0	0.0	0	4	610	24	400	16	-	-

- [1] The total height does not include the cap thickness. The total height measurement refers to the vertical distance between the top of the leveling pad (aggregate base) and the top of the uppermost course.
- [2] The optimal conditions assumed for the development of this chart are the following: (i) The retained soil type is granular with an internal friction angle of 36 degrees; (ii) There is no presence of load applied or slope above the wall; and (iii) An adequate drainage system is provided to the wall system.
- [3] The minimum radius is measured from the center of the circle to the outer face of the wall. It corresponds to the lowest course in an internal curve and to the uppermost course in an external curve.
- [4] Fascia Wall product includes Iconic and Rosemont Fascia wall collections.

# INSTALLATION GUIDE

## SUMMARY OF CHARACTERISTICS

TYPE OF WALL	FREESTANDING WALL						PILLARS				
	MAXIMUM EXPOSED HEIGHT [2,3]		MINIMUM WALL RADIUS [4]				Maximum permissible height [2,3,5]				
			Inside		Outside		Exposed		Total		
	mm	in	mm	in	mm	in	mm	in	mm	in	
BOREALIS	612	24"	-	-	-	-	-	-	-	-	-
BRANDON 90 mm [6]	750	29 7/16"	1538	61"	1788	70"	930	36 1/2"	1080	42 1/2"	
BRANDON 180 mm [6]	750	29 7/16"	1538	61"	1788	70"	930	36 1/2"	1080	42 1/2"	
FASCIA WALL COLLECTION [7]	600	23 1/2"	-	-	-	-	750	29 7/16"	900	35 7/16"	
GRAPHIX	600	23 1/2"	-	-	-	-	1050	41 1/4"	1200	47 1/4"	
G FORCE	-	-	-	-	-	-	1069	42"	1219	48"	
MINI-CRETA 3" [6]	750	29 7/16"	907	36"	1158	46"	1050	41 1/4"	1200	47 1/4"	
MINI-CRETA 6" [6]	750	29 7/16"	907	36"	1158	46"	1050	41 1/4"	1200	47 1/4"	
PRESCOTT 2.25" [6]	650	25 1/2"	863	34"	1114	44"	993	39"	1143	45"	
PRESCOTT 4.5" [6]	650	25 1/2"	863	34"	1114	44"	993	39"	1143	45"	
RAFFINATO 90 mm [6]	750	29 7/16"	2259	89"	2510	99"	930	36 1/2"	1080	42 1/2"	
RAFFINATO 180 mm [6]	750	29 7/16"	2259	89"	2510	99"	930	36 1/2"	1080	42 1/2"	
RÖCKA	612	24"	-	-	-	-	-	-	-	-	
SEMMMA [6]	750	29 7/16"	519	20"	807	32"	1050	41 1/4"	1200	47 1/4"	
SYSTEMA	750	29 7/16"	-	-	-	-	930	36 1/2"	1080	42 1/2"	
TRAVERTINA RAW [6]	612	24"	-	-	-	-	917	36"	1067	42"	

- [1] Vertical Retaining walls are constructed without any face inclination or setback.
- [2] Heights do not include cap thickness.
- [3] - Total Height is the vertical distance measured from the top of the footing (aggregate base) to the top of the uppermost course.  
 - Exposed Height is the vertical distance measured from the finished grade at the bottom of the wall to the top of the uppermost course. It does not include the wall depth below grade (embedment).
- [4] Freestanding Minimum Wall radius based on the shortest tapered unit.
- [5] The maximum height does not necessarily correspond to the amount of blocks in a pallet.
- [6] Pillar units sold separately.
- [7] Fascia Wall product includes Iconic and Rosemont Fascia wall collections.



# COMPATIBILITY CHART

Walls & Pillars	Caps																				
	Architectural cap	Brandon cap	Bullnose	Bullnose Grande	Graphix cap	Limestone	Piedimonte	Piedimonte 28"x28"	Portofino	Raffinato 60 mm	Raffinato 90 mm	Sandstone	Sandstone Bullnose	Sandstone Overlay	Terrazzo	Terrazzo Bullnose	Travertina Raw 14"x28"	York	York 28"x28"	York 32"x32"	
Borealis (does not require a cap)																					
Brandon 90 & 180 mm		x	x	x		x	x		x	x	x	x	x	x	x	x	x	x			
Brandon 90 & 180 mm pillar						x		x		x	x	x					x		x		
Fascia Wall Collection - single-sided	x	x	x	x	x	x	x		x	x	x	x	x	x	x	x	x	x			
Fascia Wall Collection - double-sided									x												
G-Force						x	x	x		x	x	x			x	x	x				
Graphix					x	x	x			x	x	x		x	x	x	x				
Mini-Creta Collection	x	x	x	x		x	x		x	x	x	x	x	x	x	x	x	x			
Mini-Creta Pillar 24" Collection						x		x		x	x	x					x		x		
Prescott Collection						x	x		x	x	x	x		x	x	x	x	x			
Prescott Pillar Collection						x		x		x	x	x					x		x		
Raffinato Collection				x	x	x	x			x	x	x	x	x	x	x	x	x			
Raffinato Pillar Collection						x		x		x	x	x					x				
Röcka (does not require a cap)																					
Semma	x	x	x		x	x	x		x	x	x	x		x	x	x	x	x			
Semma Pillar						x				x		x					x				x
Skyscraper						x				x	x	x		x	x	x					
Systema				x	x	x	x			x	x	x	x	x	x	x	x				
Travertina Raw	x	x	x	x	x	x	x		x	x	x	x	x	x	x	x	x	x			
Travertina Raw pillar						x				x	x	x					x		x		

NOTE: The combinations shown in this chart are not exclusive. Other combinations can be possible.

Applications	Caps																									
	Architectural	Bali Travertina Raw	Brandon	Bullnose	Bullnose Grande	Graphix	Limestone	Piedimonte 14"x30"	Piedimonte 28"x28"	Portofino	Raffinato 60 mm	Raffinato 90 mm	Sandstone	Sandstone Bullnose	Sandstone Overlay	Terrazzo	Terrazzo Bullnose	Travertina Raw 14"x28"	York wall caps 16", 32", 48"	York 14"x48"	York 24"x36"	York 28"x28"	York 32"x32"	Blu 45 mm	Venetian	
Step	x		x	x	x	x	x	x		x	x	x	x	x		x	x	x	x	x						
Concrete & step overlay system															x										x	x
Pool coping		x		x	x			x		x	x	x	x	x	x	x	x	x	x							
Wall single-sided	x		x	x	x	x	x	x		x	x	x	x	x	x	x	x	x	x	x						
Wall double-sided	x					x	x	x		x	x	x						x	x	x						
Counter top								x	x									x								
Pillar								x		x								x				x	x	x		

# INSTALLATION GUIDE

## RETAINING WALLS

### INSTALLATION OUTLINE

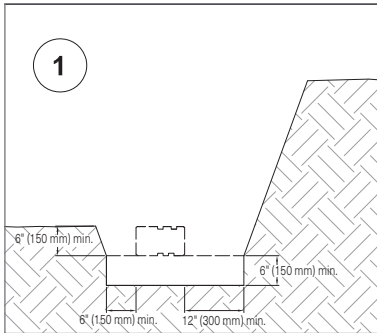

#### 01 EXCAVATION

- A. Check the location of existing structures and utilities before starting the excavation.
- B. Dig out a trench. Its depth should be calculated according to the thickness of the leveling pad and the burial depth of the wall.
- C. Plan for a thickness of at least 6" (150 mm) for the leveling pad and consider that at least 10% of the height of the wall should be buried in the ground. In all cases, the wall must be buried no less than 6" (150 mm) deep.
- D. In determining the width of the trench, allow for a space of at least 6" (150 mm) at the front of the wall and 12" (300 mm) at the back. Compact and level the excavation base.



#### FOR GEOGRID REINFORCED RETAINING WALLS

The excavation must also take into account the length of geogrid.

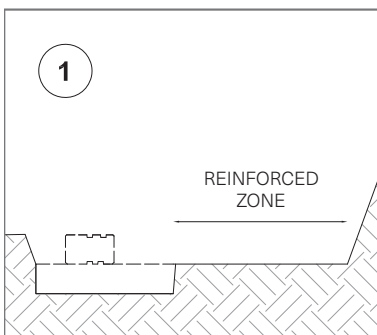

#### 02 FOUNDATION

- A. Cover the base and back of the trench with a geotextile. Extend the geotextile towards the back of the excavation and eventually above the drainage fill once it is in place close to the top of the wall.
- B. Next, spread the 0-3/4" (0-20 mm) stone in the trench and compact using a vibratory plate or jumping jack, ensuring that the surface is level. The compacted leveling pad must be at least 6" (150 mm) thick.

#### NOTE FOR STEPPED FOUNDATION

A wall built on an incline requires stepped foundations. For steep inclines, several steps may be required. Construction should start at the lowest level. Each of the steps must follow a level horizontal path and the vertical distance separating the successive steps must equal the height of a block.

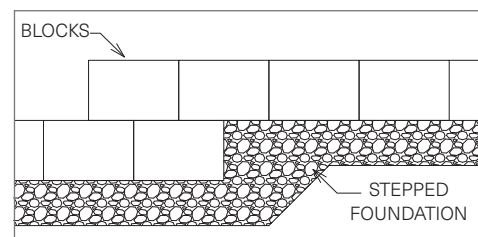
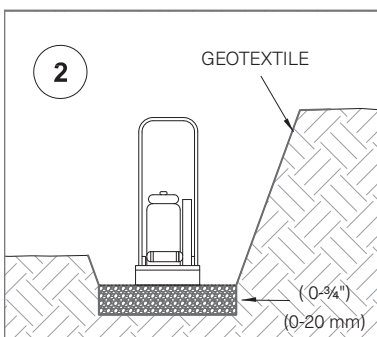

# INSTALLATION GUIDE

## RETAINING WALLS

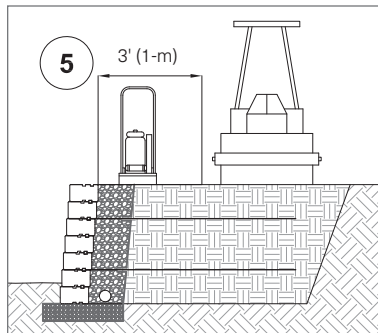
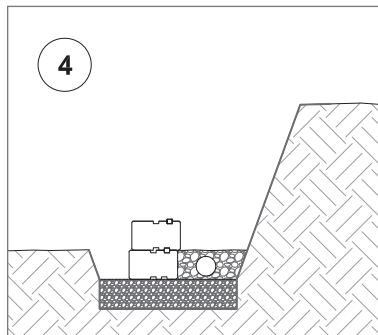
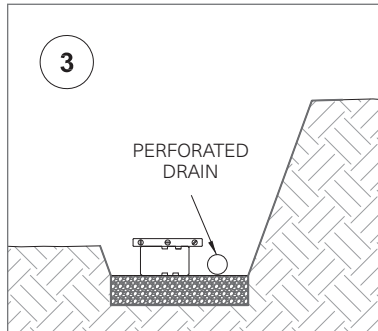

### 03 BUILDING THE FIRST COURSE

- Using blocks of the same height, place the first course on the compacted leveling pad according to the predetermined layout. Check the alignment and leveling in all directions and make sure that all the blocks are in full contact with the leveling pad and properly supported.
- Place the exposed surfaces of the blocks side by side. There must be no space between the exposed faces of adjacent blocks.
- At the back of the wall and on the compacted leveling pad, lay a 4" (100 mm) diameter perforated drain. Connect this drain to the existing drainage system so that it clears the water accumulated behind the wall.

### 04 BACKFILLING

Backfill at the rear of the wall and the space between the back of the blocks with  $\frac{3}{4}$ " (20 mm) clean stone. Use a minimum of 12" (300 mm) of clean stone behind the wall unit, but not less than a minimum of 24" (600 mm) from the face of the wall. Level and settle the clean stone. Any cavities in the blocks must also be filled with clean stone.

### 05 SUBSEQUENT COURSES

- Clean the top of each block before laying the next course. Depending on the type of block, install the connectors on the extremity of each block.
- Lay the subsequent courses, backfilling at the rear of the wall every 8" (200 mm maximum), using the same method outlined in step 4.
- Make sure the subsequent courses are laid such that the vertical seams are aligned with the blocks below.

### FOR GEOGRID REINFORCED RETAINING WALLS



Where geogrids are to be used, cover the clean stone with a geotextile. Select the geogrid according to the type, level and appropriate length. Position the geogrid according to the main reinforcement direction perpendicular to the wall. The geogrid must be continuous all along its embedment length. Splicing of the geogrid in the main reinforcement direction is not permitted. The geogrid must be installed horizontally over the compacted backfill and the previous course of blocks. Fix the connectors on the geogrid and lay the next course of blocks. Pull on the back of the geogrid and maintain its tension by stakes or pins. Repeat with a new section of geotextile and place the reinforced backfill directly behind the drainage fill. Fill and compact up to the level of the blocks.

Heavy equipment must not be used less than 3' (1-m) behind the blocks. Construction equipment must not drive directly over the geogrid. Repeat the various installation steps.

### 06 FINISHING

Position the course of coping stones (if applicable) or the final course of blocks to complete the wall. The coping stones or final course of blocks must be fixed to the subjacent blocks using concrete adhesive and there must be no space between the blocks.

# INSTALLATION GUIDE

## RETAINING WALLS

### CAP UNIT - DRIP GROOVE

While optional, drip groove applied to the underside of wall cap units is beneficial to reduce the potential of leaving water marks and stains on the wall surface (retaining or freestanding wall). Rain water will run underneath the cap unit, reach the drip groove and fall directly to the ground, instead of continuing to run underneath the cap and down the wall.

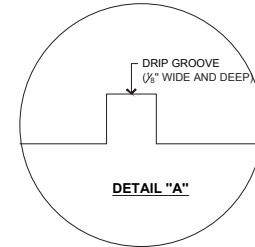
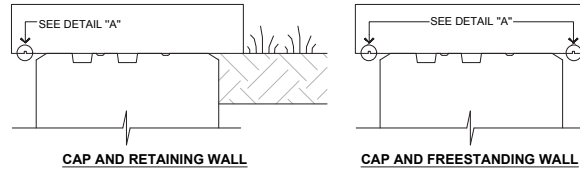

### GRAVITY WALL

Typical cross section

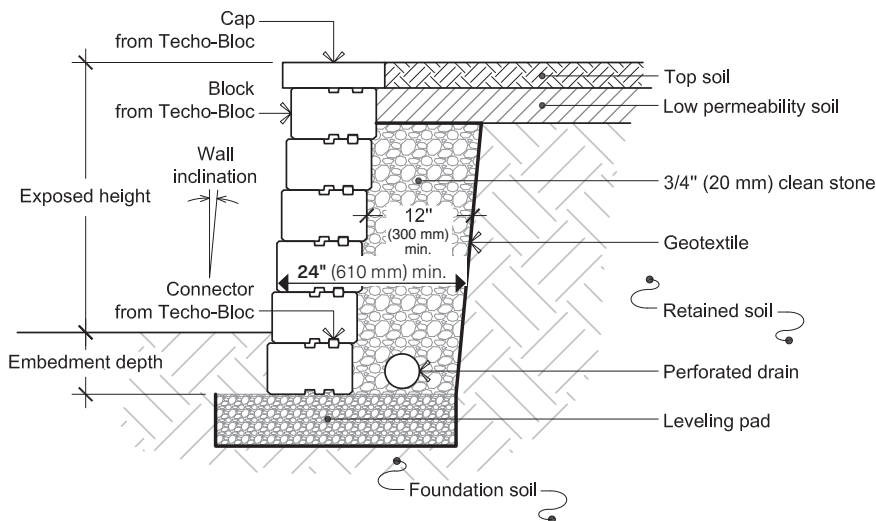

### GEOGRID REINFORCED WALL

Typical cross section

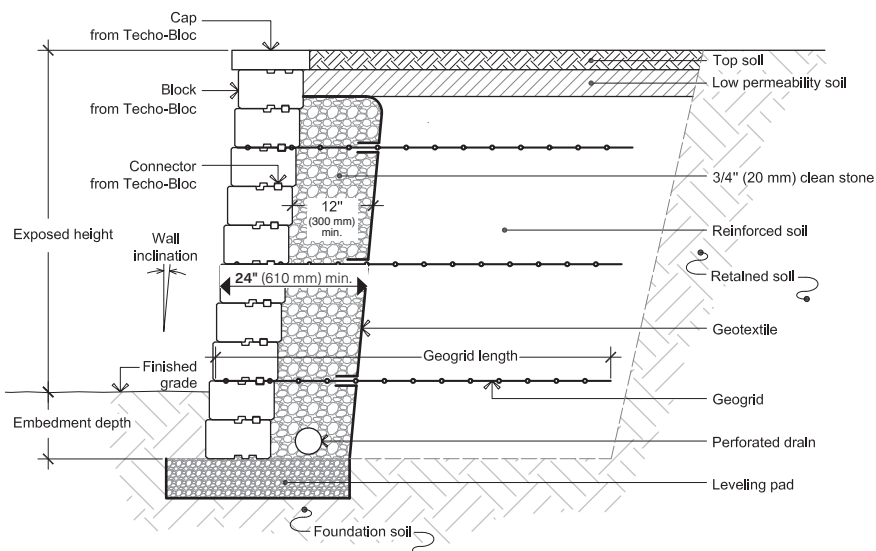

# INSTALLATION GUIDE

## RETAINING WALLS

### ANCHORING SYSTEMS

#### BRANDON 180 mm

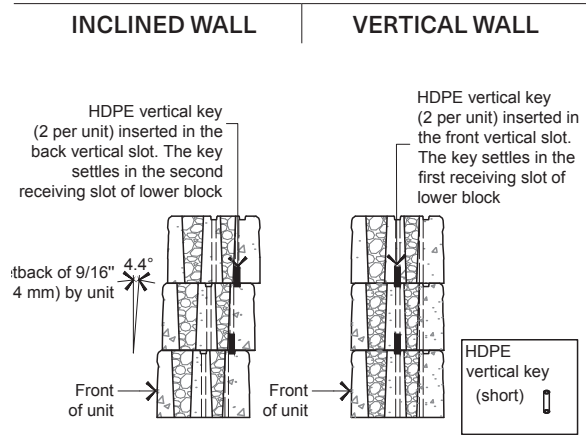

BRANDON 180 mm IS EQUIVALENT TO TWICE THE BRANDON 90 mm

#### FASCIA WALL COLLECTION

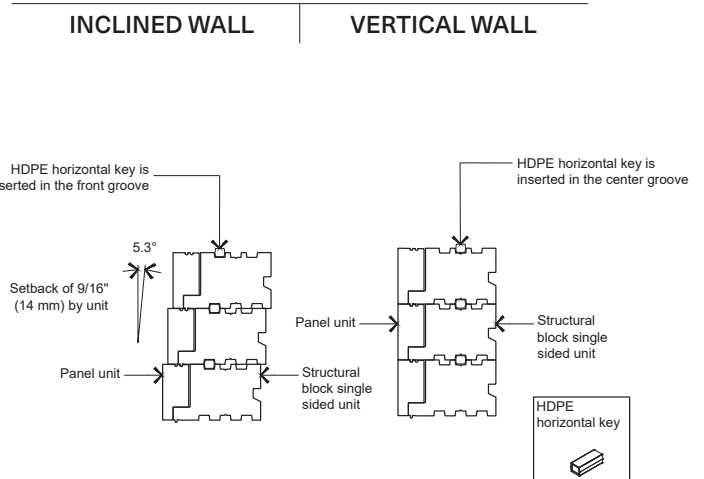

#### G-FORCE

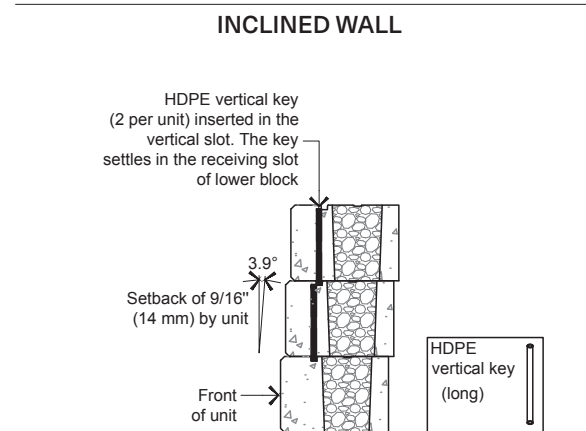

#### GRAPHIX

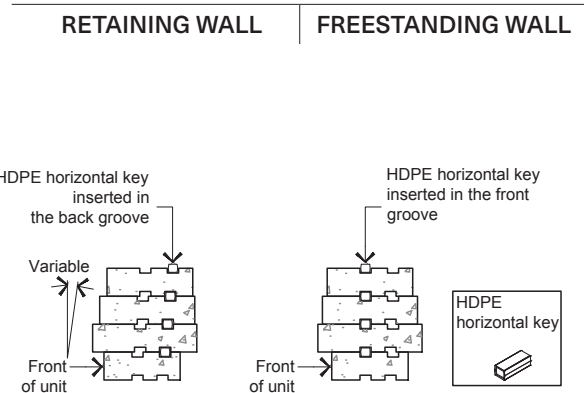

#### MINI-CRETA 6"

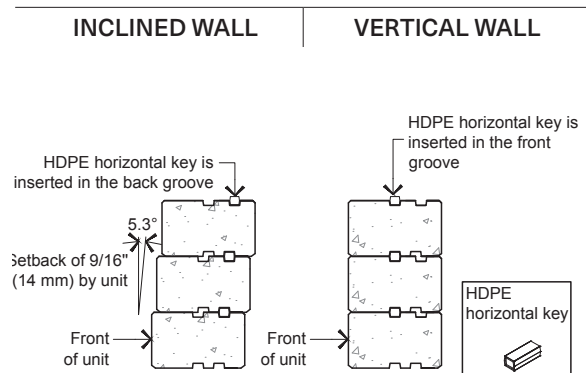

#### PRESCOTT 4.5"

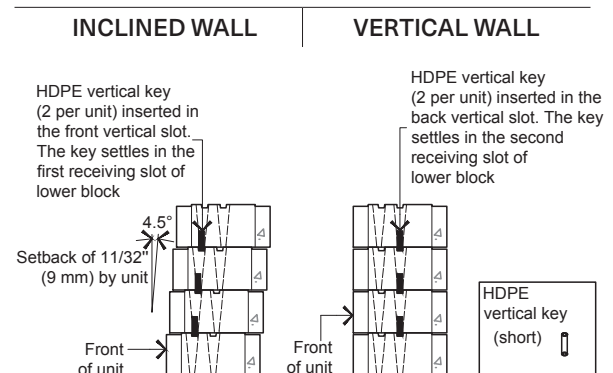

PRESCOTT 4.5" IS EQUIVALENT TO TWICE THE PRESCOTT 2.25"

# INSTALLATION GUIDE

## RETAINING WALLS

### ANCHORING SYSTEMS

#### RAFFINATO 180 mm

INCLINED WALL

VERTICAL WALL

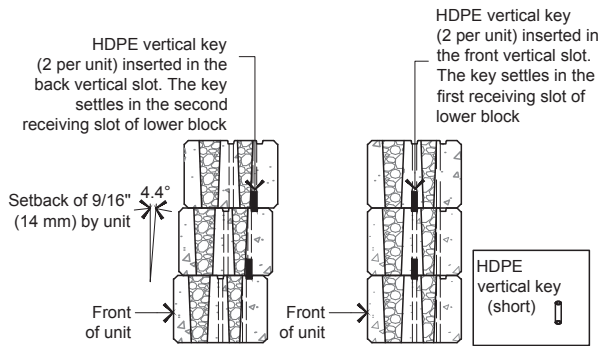

RAFFINATO 180 mm IS EQUIVALENT TO TWICE THE RAFFINATO 90 mm

#### SEMMA

INCLINED WALL

VERTICAL WALL

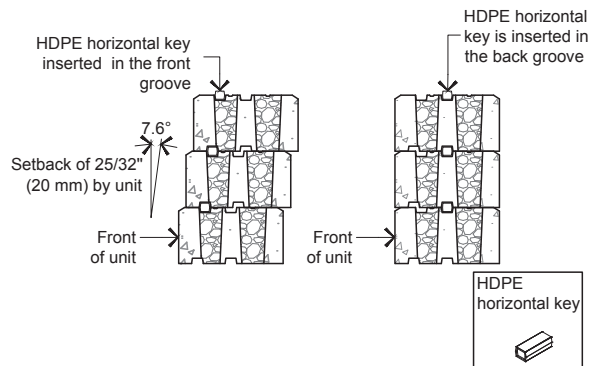

#### SKYSCRAPER

INCLINED WALL

VERTICAL WALL

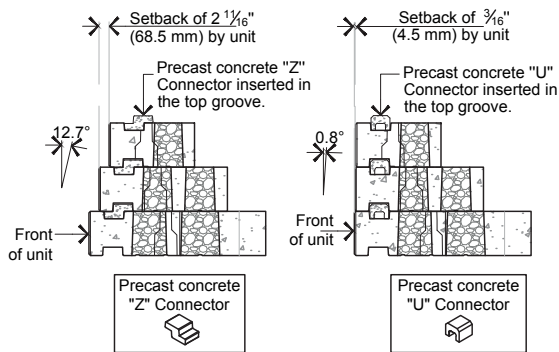

#### SYSTEMA

PATENT PENDING

INCLINED WALL

VERTICAL WALL

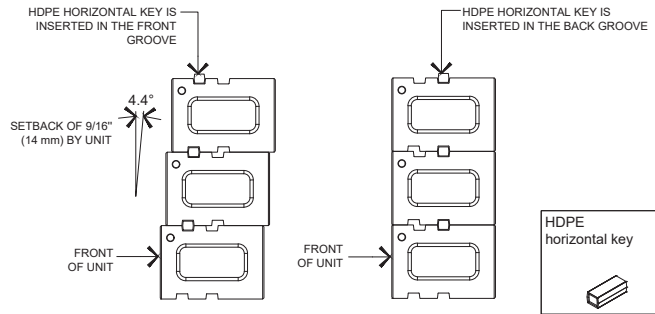

#### TRAVERTINA RAW

INCLINED WALL

VERTICAL WALL

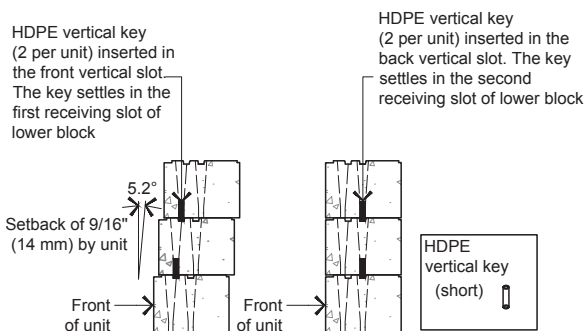

# INSTALLATION GUIDE

## RETAINING WALLS

### ANCHORING SYSTEM | CONNECTORS IN CURVED WALL APPLICATION

#### HDPE Horizontal Key

When creating internal curves and the HDPE horizontal keys are in the back groove, two connectors must be installed on each block as illustrated.

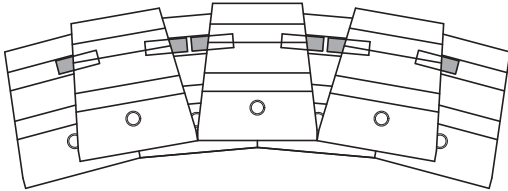

#### HDPE Vertical Key

When creating curves using HDPE vertical keys adjust placement in field to achieve desired curve.

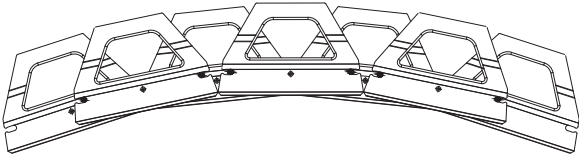

#### Precast concrete "U" Connector

When creating internal curves with the precast concrete "U" connector, place one connector on top center of each lower course block and adjust placement in field to achieve desired curve.

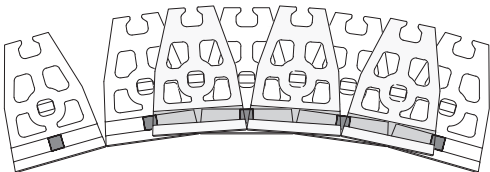

#### Precast concrete "Z" Connector

When creating internal curves with the precast concrete "Z" connector, place one connector on top center of each lower course block and adjust placement in field to achieve desired curve.

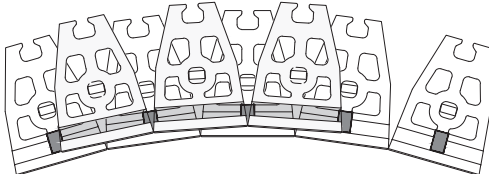

### ANCHORING SYSTEM | CONNECTORS IN GEOGRID REINFORCED WALL APPLICATION

#### HDPE Horizontal Key

When installing a geogrid, using HDPE horizontal keys, it must be placed above the connectors. The connectors will therefore be placed before the geogrid. After positioning the geogrid, move the block (from the above course) forward until it touches the connectors and ensures that the system is locked.

# INSTALLATION GUIDE

## RETAINING WALLS

### HDPE Vertical Key

When installing geogrid, using HDPE vertical keys, it must be placed immediately above the lower course block. The connectors will be inserted in the vertical slots of the upper course blocks. Ensure that pin all ways settles into the receiving slot of the lower course block and not on the geogrid. Once the pin settles, move forward the upper block until it touches the connectors and ensures that the system is locked.

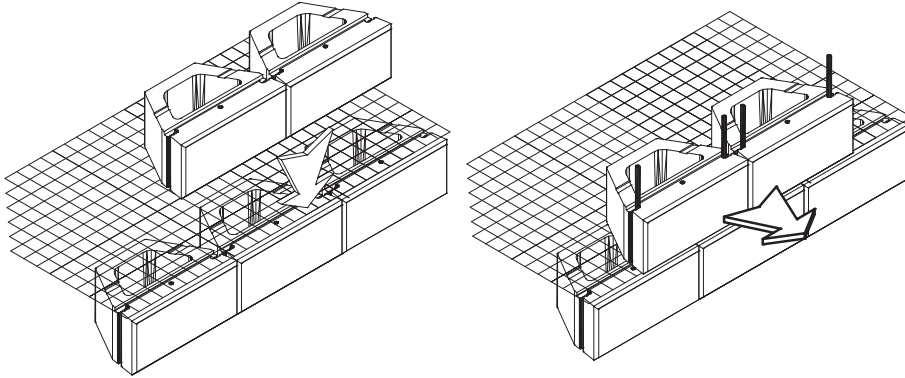

## INTERNAL CORNER

When building a wall with an internal corner, it is recommended to start constructing the wall at the corner and build out from this point in both directions. To form the corner, use the longer modules as illustrated. Build wall B by extending it out from wall A so the end of wall B is aligned with the back of wall A. For subsequent courses, simply alternate the extension of walls A and B.

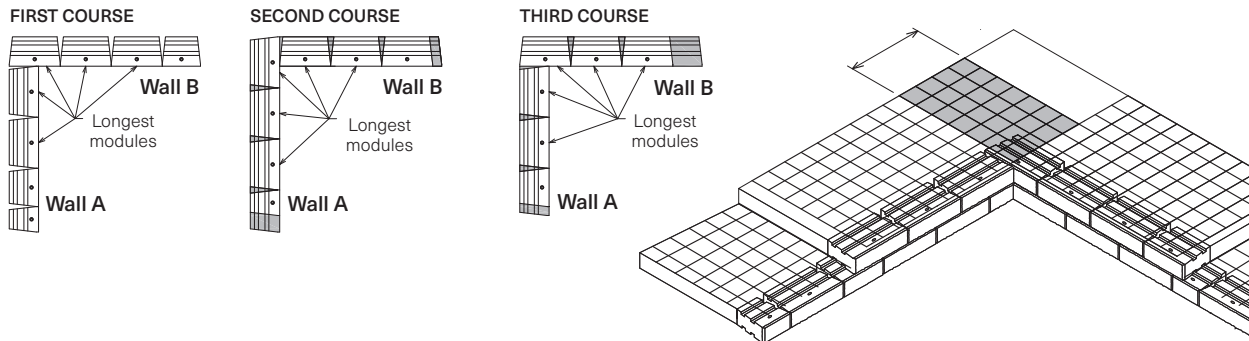

When using geogrid, it must be extended beyond the internal corner by at least 25% of the total height of the wall. Alternate the extension of the geogrid for subsequent layers (as illustrated in grey)

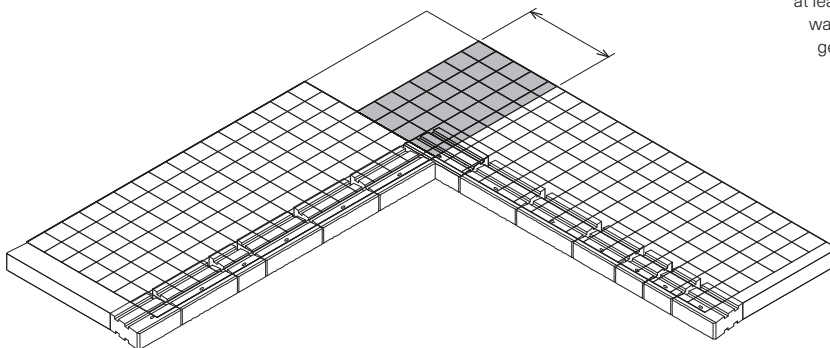

# INSTALLATION GUIDE

## RETAINING WALLS

### EXTERNAL CORNER

For walls with an external corner, start building the wall from the corner and continue from this point in both directions. For each subsequent course, alternate the direction of the corner unit and secure the corner unit to the block below using concrete adhesive.

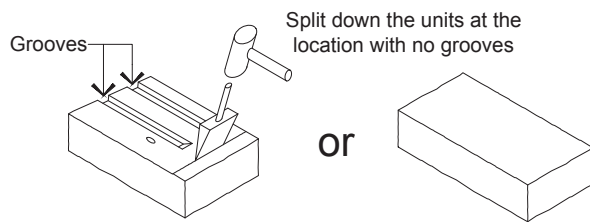
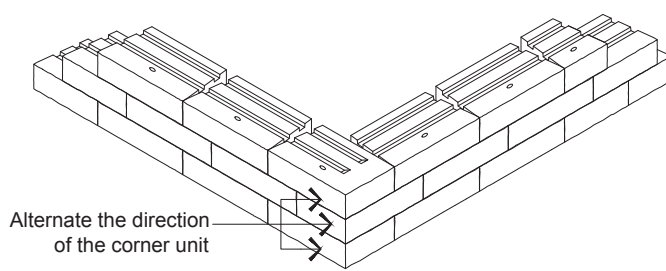

Use corner unit with finish already available on the side

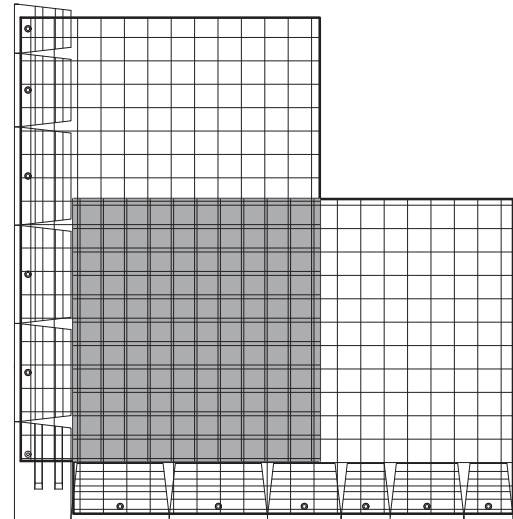

When overlapping two geogrids in the same layer (as illustrated by shaded area) allow at least 3" (75 mm) of backfill in between the

### OBLIQUE CORNER

The longer modules should be used to build an oblique external corner. Alternatively, corner can be replaced by a curve.

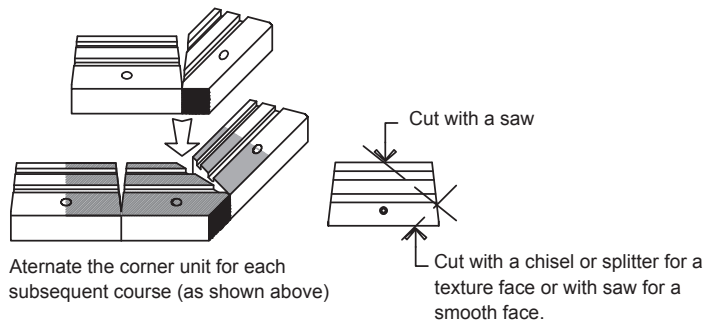
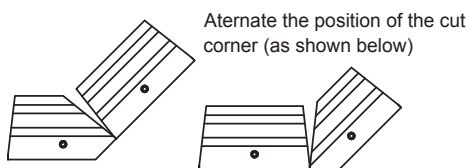

**Note:** Cut face finish may differ from original face finish

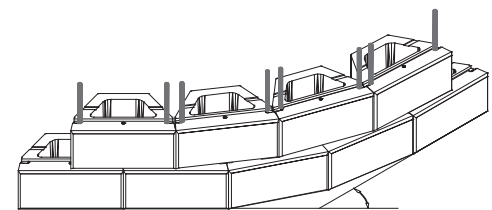
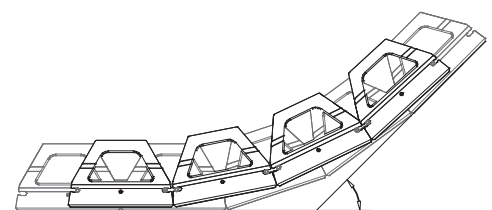

**Note:** Adjust placement in field to achieve desired angle

# INSTALLATION GUIDE

## RETAINING WALLS

### INTERNAL CURVE

The Techo-Bloc retaining wall system allows walls to be built with internal and external curves. These curves can be achieved without cutting the blocks. You will need to angle the curves according to the minimum radius specified by Techo-Bloc.

When building a wall with an internal curve, it is recommended to start building the wall at the center of the curve and place blocks alternately to the left and right of the central block. If the wall to be constructed requires a setback (inclined wall), each course should be offset to the back and the curve will then become bigger. The minimum radius is therefore that of the first course.



When using geogrid, it must cover 100% of the surface around the curve. To do this, additional layers of geogrid are placed on the next course of blocks to fill voids created from previous course (as illustrated in green).

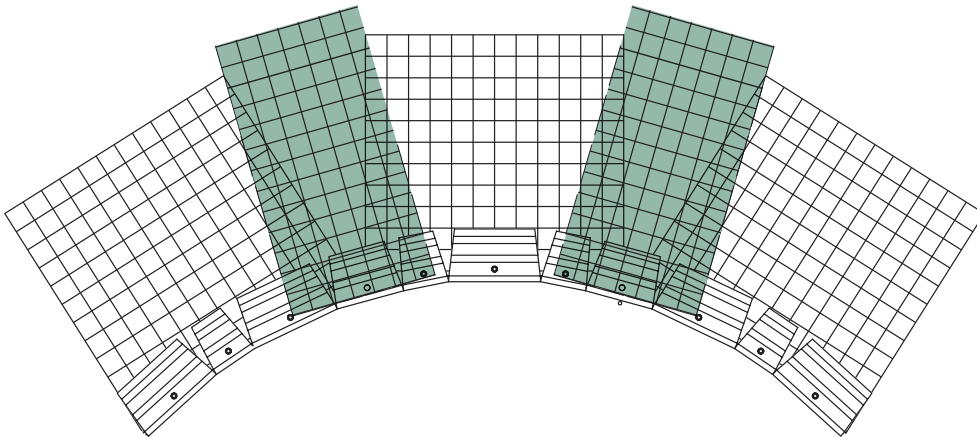

# INSTALLATION GUIDE

## RETAINING WALLS

### EXTERNAL CURVE

When building a wall with an external curve, it is recommended to start building the wall at the center of the curve and place blocks alternately to the left and right of the central block. Unlike internal curves, the external curve gets smaller as courses are added. The minimum radius is therefore that of the last course.

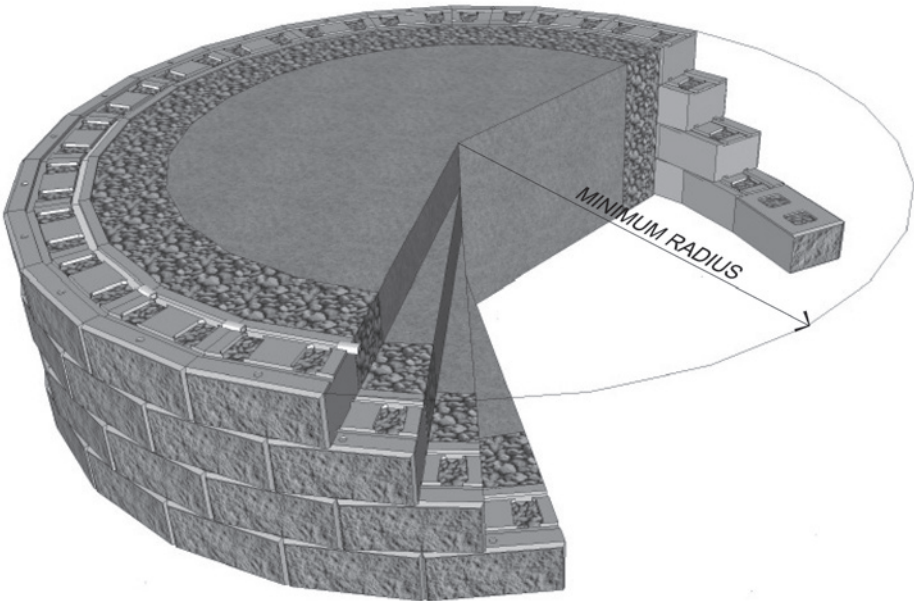

When using geogrid, it must cover 100% of the surface around the curve. To achieve this, additional layers of geogrid are placed on the same course of blocks to fill voids (as illustrated in green). In this case, we recommend at least 3" (75 mm) of backfill in between the overlapping sections.

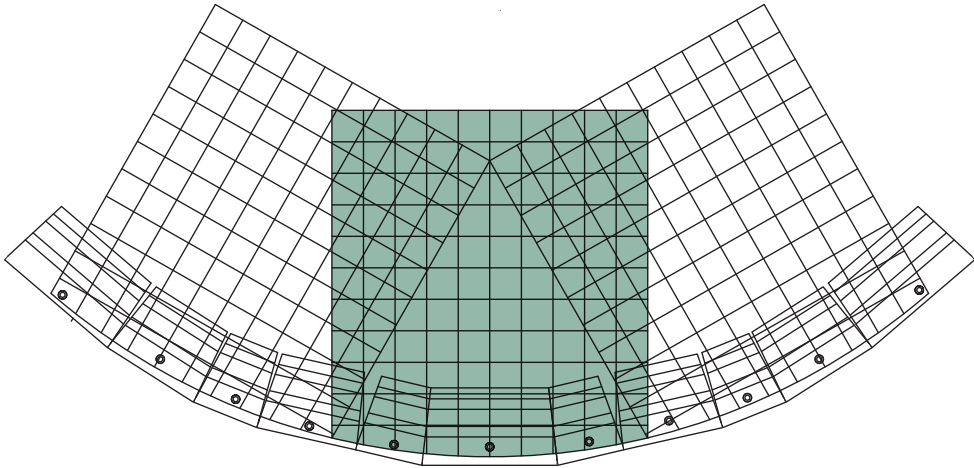

# INSTALLATION GUIDE

## RETAINING WALLS

### FENCING

Fencing can be erected behind the blocks. Fence posts must be placed in formwork tubes positioned during construction of the wall and then filled with concrete. The geogrid may be cut to accommodate installation of the tubes. Cut the geogrid in alignment with the center of the formwork tube and perpendicular to the wall, thus creating two geogrid panels. Connect the two geogrid panels at the front and back of the formwork tube and bend the geogrid to fit around the formwork.

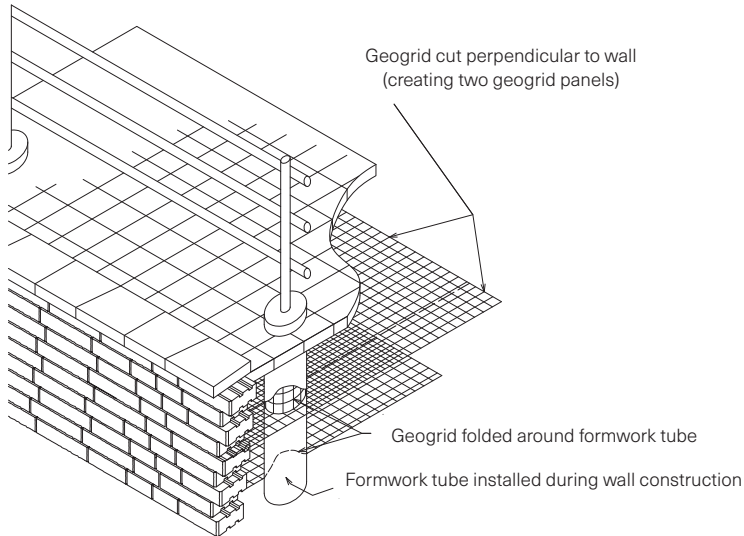

### GUARD RAIL

As with fencing, a guardrail can be incorporated behind the blocks. The guardrail posts must be installed during construction of the wall. The geogrid is cut perpendicular to the wall and in alignment with the center of the post, thus creating two geogrid panels. These two panels are connected at the front and back of the post. The geogrid can be bent to fit around the post.

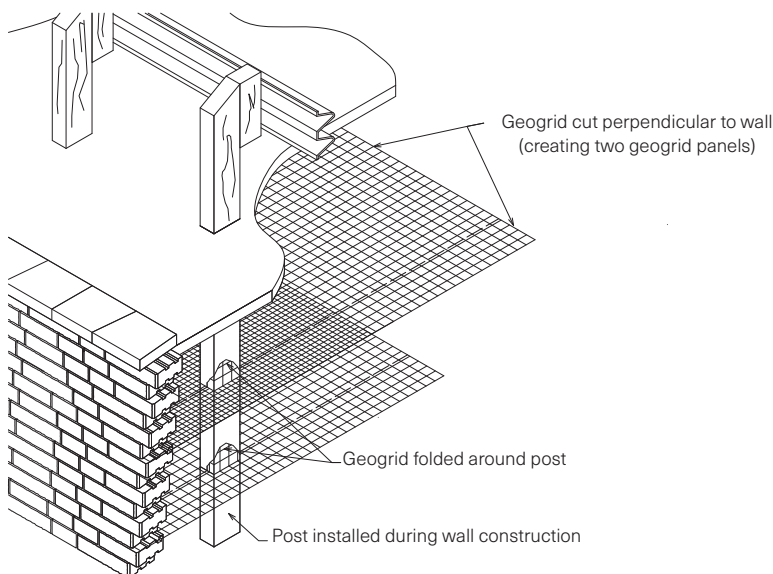

# INSTALLATION GUIDE

## RETAINING WALLS

### TIERED WALL

Although tiered walls look appealing, it is important to take into account the additional load the upper wall applies on the lower wall. If the distance between the walls is at least twice the height of the lower wall, the walls are generally independent of each other. However, if this distance is less the lower wall must be built to take account of the load of the upper wall and geogrids may be required.

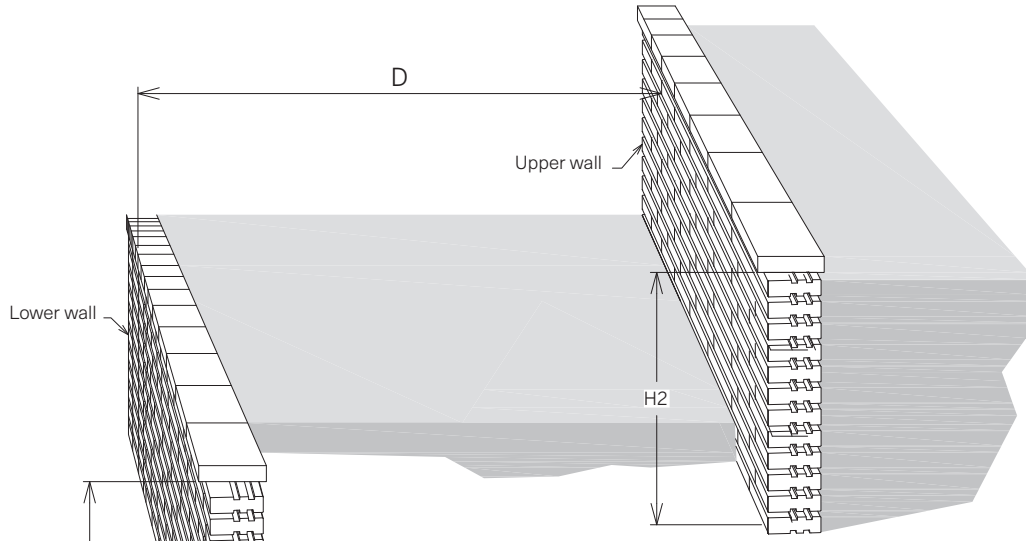

**If  $H1 > H2$  and  $D > (H1 \times 2)$**

The walls are generally independent of each other. Otherwise, the construction of the lower wall must take into account the load of the upper wall (as shown below).

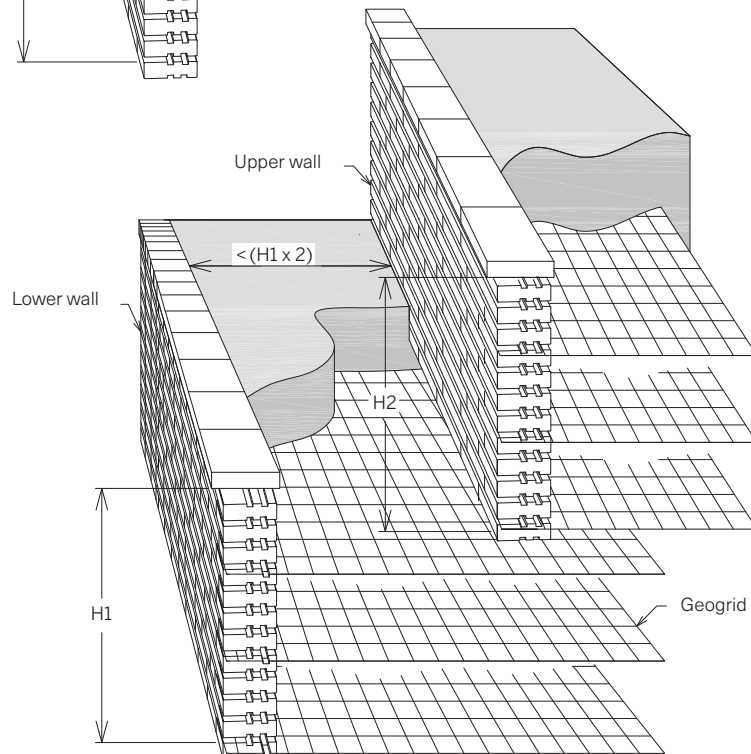

# INSTALLATION GUIDE

## FREESTANDING WALLS

### INSTALLATION OUTLINE

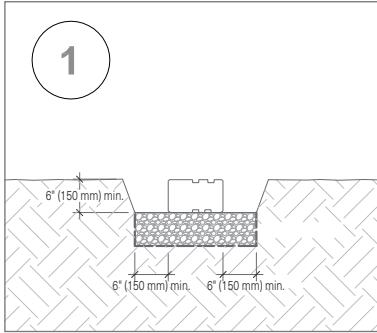

#### 01 EXCAVATION

- A. Check the location of existing structures and utilities before starting the excavation.
- B. Dig out a trench. The trench should be 12" wider than the block width (6" (150 mm) at the front and at the back of the wall).
- C. The trench should be a minimum 12" (300 mm) deep. This depth will provide 6" (150 mm) for the compacted base and a minimum 6" (150 mm) free-standing wall embedment.
- D. In areas where unstable soils or one particularly affected by freeze-thaw cycles, a thicker compacted base may be necessary.
- E. The foundation soil should be checked to make sure it is firm, level and capable of supporting the freestanding wall.

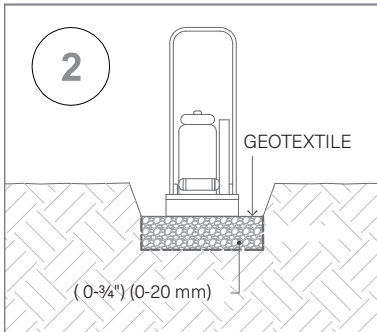

#### 02 FOUNDATION

- A. Cover the excavated area with a geotextile. Create a leveling pad of compacted aggregate base material. The pad should be composed of 0-3/4" (0-20 mm) crushed stone with a minimum thickness of 6" (150 mm).

#### NOTE FOR STEPPED FOUNDATION

A wall built on an incline requires stepped foundations. For steep inclines, several steps may be required. Construction should start at the lowest level. Each of the steps must follow a level horizontal path and the vertical distance separating the successive steps must equal the height of a block.

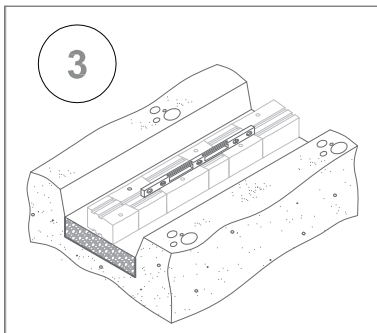

#### 03 BUILDING THE FIRST COURSE

- A. Using blocks of the same height, place the first course on the compacted leveling pad according to the predetermined layout. Check the alignment and leveling in all directions and make sure that all the blocks are in full contact with the leveling pad and properly supported.
- B. Place the blocks side by side. There must be no space between adjacent blocks. For alignment of straight walls, use a string line aligned on the connector's slots of applicable units, or back of the block of full solid units.
- C. For tapered units, alternate front and back faces to obtain straight walls.

# INSTALLATION GUIDE

## FREESTANDING WALLS

### INSTALLATION OUTLINE

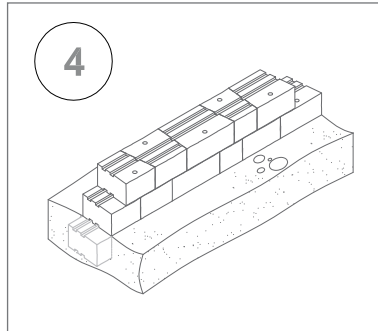

#### 04 SUBSEQUENT COURSES

- A. Clean the top of each block before laying the next course. Depending on the type of block, install the connectors if available on each block.
- B. Stagger joints from one row to the next.
- C. Glue all modules at each row with a concrete adhesive for securing.
- D. All Free-standing walls must be installed in vertical position.
- E. Any cavities in the blocks must be filled with  $\frac{3}{4}$ " (20 mm) clean stone.
- F. Continue building to the desired and permissible height.

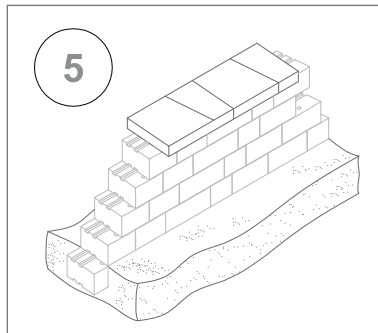

#### 05 FINISHING

- A. Position the cap units (if applicable) or the final course of blocks to complete the wall. The cap units (if applicable) or final course of blocks must be fixed to the subjacent blocks using concrete adhesive and there must be no space between the blocks.

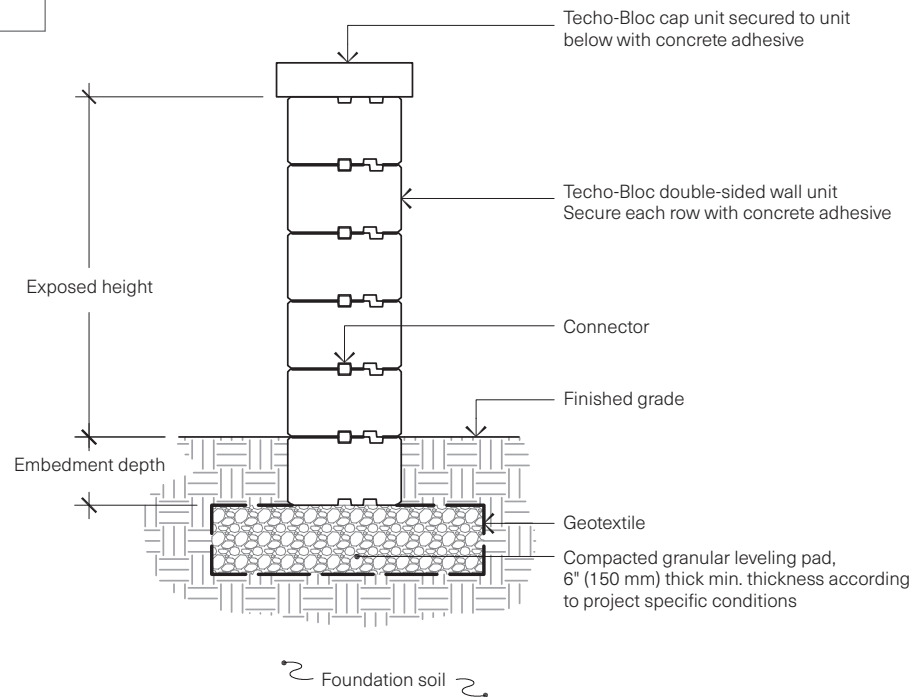

# INSTALLATION GUIDE

## PILLARS

### GENERAL NOTE

It is important to adequately glue each row with a concrete adhesive in order to obtain a stable pillar.

If you are planning to install a light on top of the pillar, make sure you run the electrical wires prior to installing the blocks.

If you are planning to build a pillar with a planter, make sure to install a geotextile membrane inside the pillar before filling the cavity with planting soil.

### INSTALLATION OUTLINE

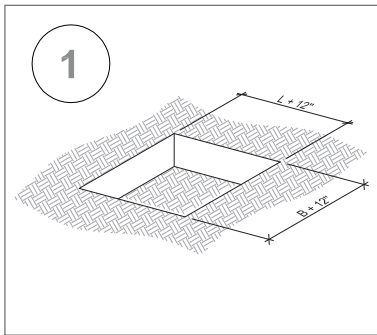

#### 01 EXCAVATION

- Check the location of existing structures and utilities before starting the excavation.
- Excavate an area that is 12" (300 mm) wider than the pillar (6" [150 mm] at each side of the pillar).
- The excavated area should be a minimum 12" (300 mm) deep. This depth will provide 6" (150mm) for the compacted base and a minimum 6" (150 mm) of embedment.
- In areas where unstable soils or one particularly affected by freeze-thaw cycles, a thicker compacted base may be necessary.
- The foundation soil should be checked to make sure it is firm, level and capable of supporting the pillar.

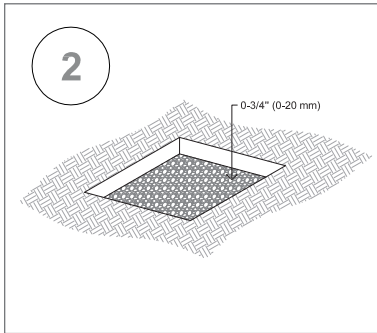

#### 02 FOUNDATION

- Cover the excavated area with a geotextile. Create a leveling pad of compacted granular base material. The pad should be composed of 0-3/4" (0-20 mm) crushed stone with a minimum thickness of 6" (150 mm).

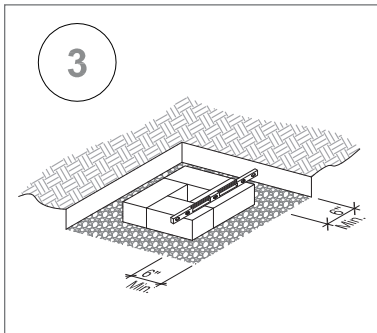

#### 03 BUILDING THE FIRST COURSE

- Using the corresponding pillar or corner units, place the first course on the compacted base according to the predetermined layout. Check the alignment and leveling in all directions and make sure that all the blocks are in full contact with the base and properly supported.

# INSTALLATION GUIDE

## PILLARS

### INSTALLATION OUTLINE

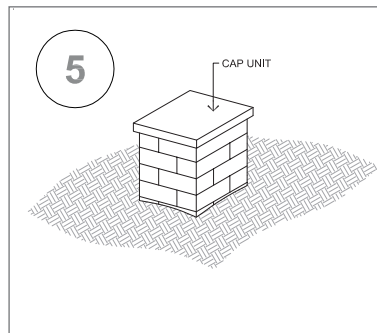
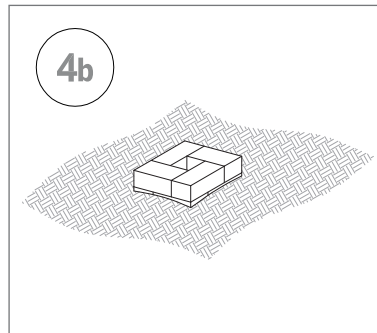
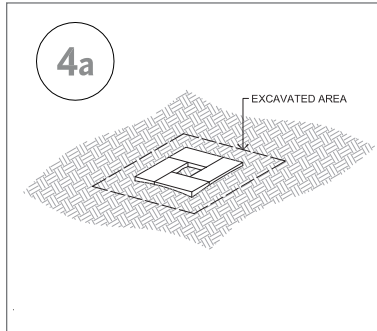

#### 04 SUBSEQUENT COURSES

- Clean the top of each block before laying the next course.
- Stagger joints from one row to the next.
- Glue all modules at each row with a concrete adhesive for securing.
- Backfill the excavated area surrounding the pillar.
- Continue building to desired and permissible height.

#### 05 CROWNING

- Crown the pillar using Techo-Bloc Pillar cap units and securing to blocks underneath with a concrete adhesive.

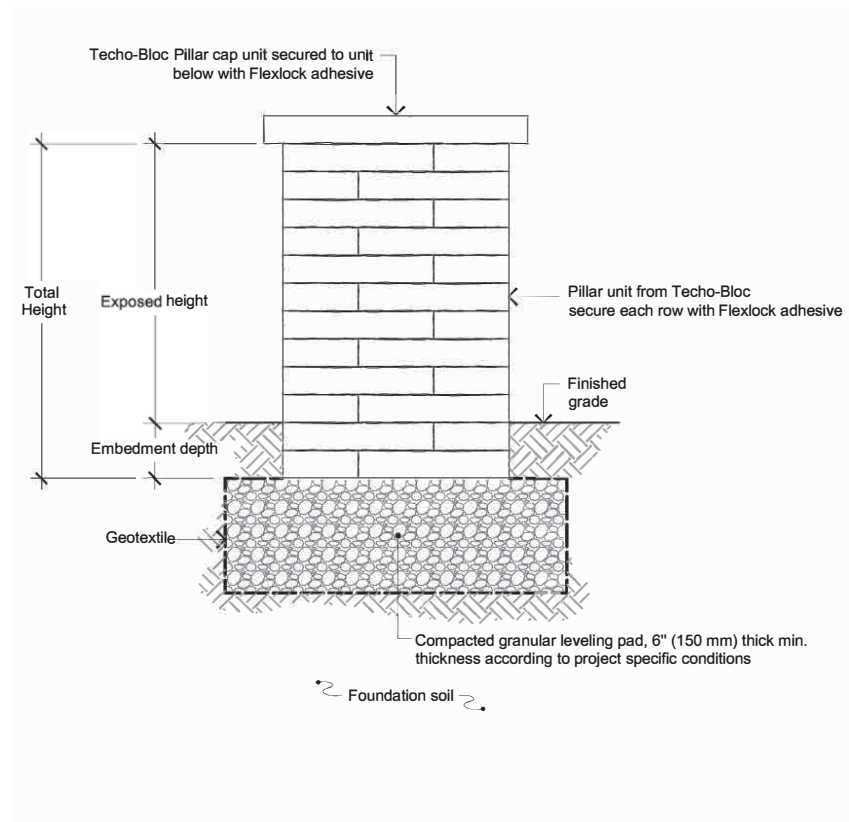



## BOREALIS Wall

DESCRIPTION: Wall TEXTURE: Wood

Specifications per pallet	Imperial	Metric
 Product dimension (L x D x H)	48 x 8 x 6	1 219 x 203 x 152
Cubing	32 ft <sup>2</sup>	2.97 m <sup>2</sup>
16 units / pallet	Linear coverage per pallet	64 lin. ft
Approx. Weight	3 042 lbs	1 380 kg
Number of rows	4	
Coverage per row	8 ft <sup>2</sup>	0.74 m <sup>2</sup>
Coverage per unit	2 ft <sup>2</sup>	0.19 m <sup>2</sup>
Linear coverage per unit	4 lin. ft	1.22 lin. m

### Pallet Overview

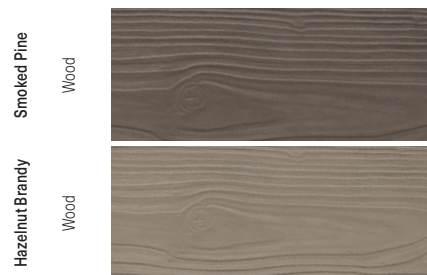
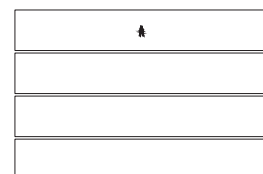

### NOTES

\*For an authentic look, each color option is composed of a variety of darker & lighter tones. Natural ingredients such as granite are present within the recipe to allow for a range in tones, veining and textures from one stone to another.

The dimensional tolerance for Stonedge wet cast retaining wall units is:  $\pm \frac{3}{16}$ " (5 mm) for height and  $\pm \frac{1}{2}$ " (13 mm) for length and width. During the installation, the level between adjacent wall units

will vary (usually more than for a dry cast wall unit) in order to obtain a more realistic appearance of a natural stone wall.

See page 6 for icons description.

See page 146 to 161 for more technical information.

# INSTALLATION GUIDE

## FREESTANDING WALLS- BOREALIS

### BOREALIS

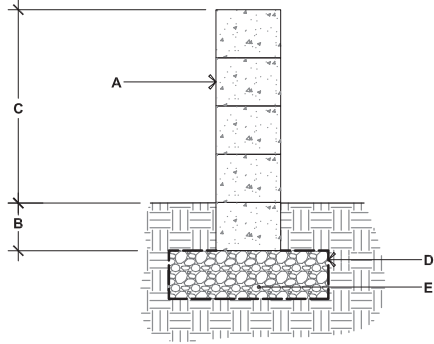

- A. BOREALIS DOUBLE-SIDED WALL UNITS  
SECURE EACH ROW WITH CONCRETE ADHESIVE
- B. EMBEDMENT DEPTH, 6" (150 mm) MIN.
- C. 24" (612 mm) MAX.
- D. GEOTEXTILE
- E. COMPACTED GRANULAR LEVELING PAD, 6" (150 mm) THICK MIN. THICKNESS  
ACCORDING TO PROJECT SPECIFIC CONDITIONS

## 90° CORNER OF A DOUBLE-SIDED WALL

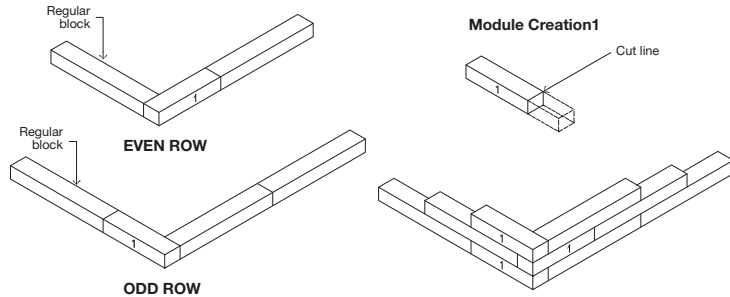

1. Alternate odd and even rows.
2. Stagger joints from one row to the next.
3. Glue all modules at each row with Concrete adhesive.

## DOUBLE-SIDED WALL - END OF A STRAIGHT WALL

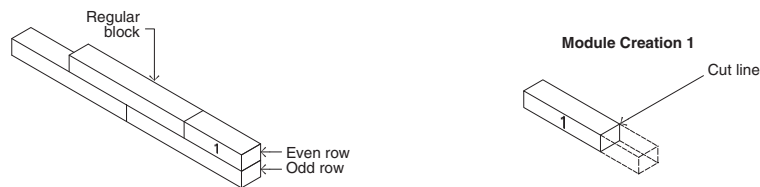

# INSTALLATION GUIDE

## GRILL ISLAND - BOREALIS

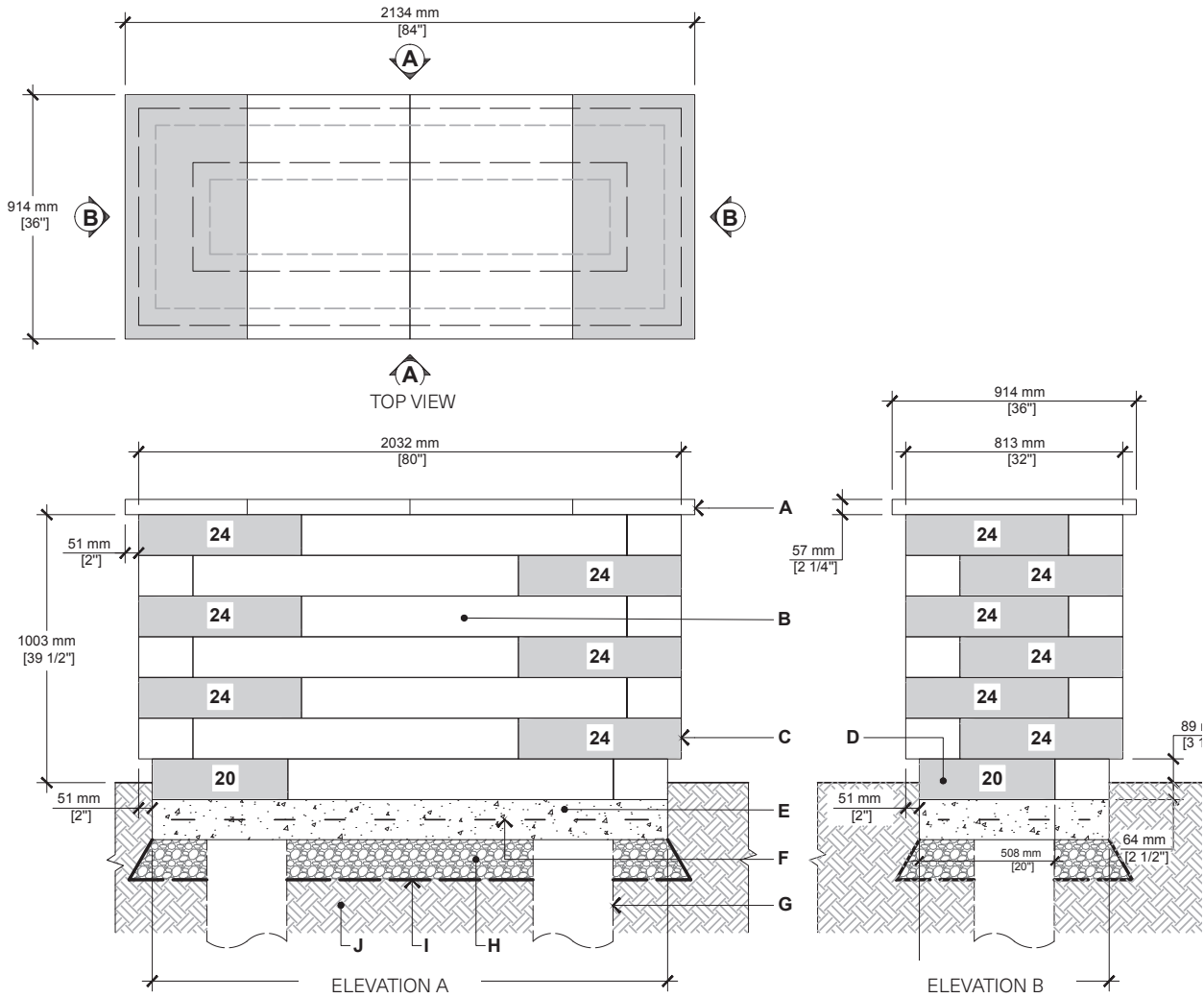

- A. YORK COUNTER TOP 24" X 36" X 2 1/4" (CUT ON FIELD AS REQUIRED)
- B. BOREALIS WALL UNIT
- C. BOREALIS WALL UNIT CUT IN HALF (CUT ON FIELD)
- D. BOREALIS WALL UNIT (CUT ON FIELD AS REQUIRED)
- E. CAST IN PLACE CONCRETE SLAB 4350 psi (30 MPa), 5" (125 mm) THICK
- F. 4X4-4/4 (102X102-MW25.8XMW25.8) WELDED WIRE MESH AND/OR REBAR AS PER SITE CONDITIONS
- G. 12" (300 mm) DIA. CONCRETE PILLAR, AS PER LOCAL CODE
- H. 3/4" (20 mm) CLEAN STONE 6" (150 mm) THICK MIN. AS PER SITE CONDITIONS
- I. GEOTEXTILE
- J. NATURAL SOIL OR COMPACTED BACKFILL

### QUANTITY OF MATERIALS REQUIRED

- York Counter top 24" x 36" x 2 1/4": **4**
- Borealis wall unit: **28**

**NOTE:** Appliances and utilities may vary for each project and are not shown on this drawing. This drawing is shown for inspiration only and surplus or shortage of materials may result. It is the user's responsibility to verify for the quantity of materials required. Secure the blocks using a heat resistant concrete adhesive. The installer must ensure that the installation and use of the grill island comply with local regulations and code requirements. Concrete pillars extending to frost line may be required as per local code. Check your local building code before installing.



D ❄️

**BRANDON 90 mm**

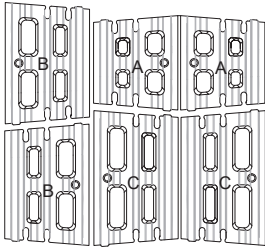

**DESCRIPTION:** Double-sided wall **TEXTURE:** Slate

**Pallet Overview**



Slate Chestnut Brown  
Slate Champlain Grey  
Slate Caffè Crema  
Slate Shale Grey  
Slate Onyx Black

**Specifications per pallet**

	Imperial	Metric
<b>A</b>  Dimension Front (L x D x H) <b>A</b>	11 ¼ x 9 13/16 x 3 9/16	285 x 250 x 90
Dimension Back (L x D x H) <b>A</b>	9 5/8 x 9 13/16 x 3 9/16	245 x 250 x 90
20 units / pallet	Dimension Front (L x D x H) <b>B</b>	14 3/8 x 9 13/16 x 3 9/16
<b>B</b>  Dimension Back (L x D x H) <b>B</b>	12 13/16 x 9 13/16 x 3 9/16	325 x 250 x 90
20 units / pallet	Dimension Front (L x D x H) <b>C</b>	15 15/16 x 9 13/16 x 3 9/16
<b>C</b>  Dimension Back (L x D x H) <b>C</b>	14 3/8 x 9 13/16 x 3 9/16	365 x 250 x 90
20 units / pallet	Cubing	20.44 ft <sup>2</sup> / 1.90 m <sup>2</sup>
	Approx. Weight	69.23 lin. ft / 21.10 lin. m
	Minimum radius	1 684 lbs / 764 kg
	Number of rows	7.5 ft / 2.3 m
	Coverage per row	10
	Lin. coverage per row	2.04 ft <sup>2</sup> / 0.19 m <sup>2</sup>
		6.92 lin. ft / 2.11 lin. m

**NOTES**

See page 6 for icons description.

**COMPATIBLE CAPS**

See page 145 for product compatibility.



When building a double-sided wall one pallet will cover an average of 19.28 ft<sup>2</sup>.

See page 146 to 161 for more technical information.



## BRANDON 180 mm

DESCRIPTION: Double-sided wall TEXTURE: Slate

Specifications per pallet		Imperial	Metric
<b>A</b> 	Dimension Front (L×D×H) <b>A</b>	11 ¼ × 9 13⁄16 × 7 1⁄16	285 × 250 × 180
	Dimension Back (L×D×H) <b>A</b>	9 5⁄8 × 9 13⁄16 × 7 1⁄16	245 × 250 × 180
	Dimension Front (L×D×H) <b>B</b>	14 3⁄8 × 9 13⁄16 × 7 1⁄16	365 × 250 × 180
10 units / pallet	Dimension Back (L×D×H) <b>B</b>	12 13⁄16 × 9 13⁄16 × 7 1⁄16	325 × 250 × 180
<b>B</b> 	Dimension Front (L×D×H) <b>C</b>	15 15⁄16 × 9 13⁄16 × 7 1⁄16	405 × 250 × 180
	Dimension Back (L×D×H) <b>C</b>	14 3⁄8 × 9 13⁄16 × 7 1⁄16	365 × 250 × 180
<b>C</b> 	Cubing	20.44 ft <sup>2</sup>	1.90 m <sup>2</sup>
		34.61 lin. ft	10.55 lin. m
	Approx. Weight	1 719 lbs	780 kg
	Minimum radius	7.5 ft	2.3 m
	Number of rows	5	
10 units / pallet	Coverage per row	4.09 ft <sup>2</sup>	0.38 m <sup>2</sup>
	Lin. coverage per row	6.92 lin. ft	2.11 lin. m

### Pallet Overview

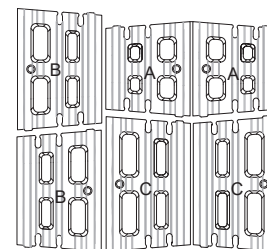

Chestnut Brown

Slate

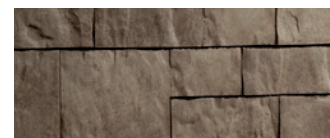

Champlain Grey

Slate



Caffè Crema

Slate

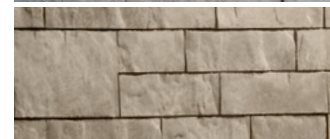

Shale Grey

Slate

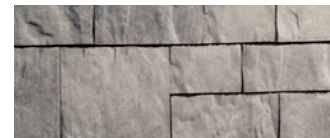

Onyx Black

Slate



### NOTES

See page 6 for icons description.

#### COMPATIBLE CAPS

See page 145 for product compatibility.

When building a double-sided wall one pallet will cover an average of 19.28 ft<sup>2</sup>.

See page 146 to 161 for more technical information.

D ❄️

## BRANDON 90 mm & 180 mm

DESCRIPTION: Pillars TEXTURE: Slate

### Pallet Overview

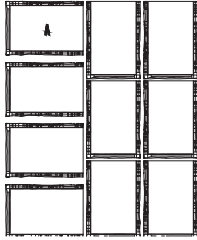

#### Pillar 90 mm

##### Specifications per pallet



40 units / pallet

	Imperial	Metric
Product dimension (L x D x H)	14 3/16 x 9 1/16 x 3 5/16	360 x 250 x 90
Cubing	40 units	40 units
Approx. Weight	1 625 lbs	737 kg
Number of rows	4	
Pillar height	35 7/16 in	900 mm

#### Pillar 180 mm

##### Specifications per pallet

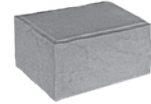

20 units / pallet

	Imperial	Metric
Product dimension (L x D x H)	14 3/16 x 9 1/16 x 7 1/16	360 x 250 x 180
Cubing	20 units	20 units
Approx. Weight	1 636 lbs	742 kg
Number of rows	2	
Pillar height	35 7/16 in	900 mm



Slate

Chestnut Brown



Slate

Champlain Grey



Slate

Caffè Crema



Slate

Shale Grey

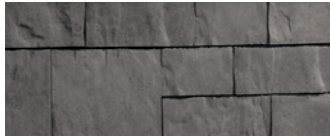

Slate

Onyx Black

### NOTES

See page 6 for icons description.

#### COMPATIBLE CAPS

See page 145 for product compatibility.

See page 146 to 161 for more technical information.

# TECHO—BLOC

## DESIGN CHART BRANDON 180 mm

(EQUIVALENT TO TWICE THE BRANDON 90 mm)

SETBACK VERTICAL

CLEAN SAND/GRAVEL/ SAND AND GRAVEL MIXES ( $\phi=34^\circ$ ,  $\gamma = 120$  pcf)  
GEOGRID: MIRAGRID 3XT BY TENCATE (RFd=1.10, RFcr=1.45, RFid=1.25, Cds=0.9, Ci=0.9)

**CASE N° 1 :**  
No Surcharge  
No Backslope  
No Toe Slope

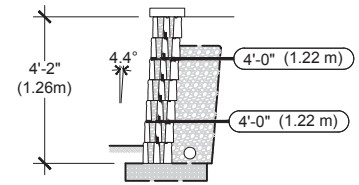
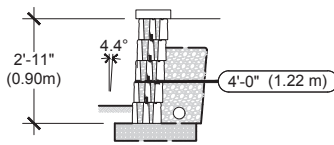
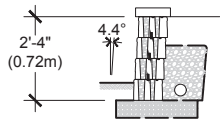

VISIT [WWW.TECHO-BLOC.COM](http://WWW.TECHO-BLOC.COM) FOR COMPLETE DESIGN CHART DOCUMENT  
(USA AND CANADA VERSIONS)

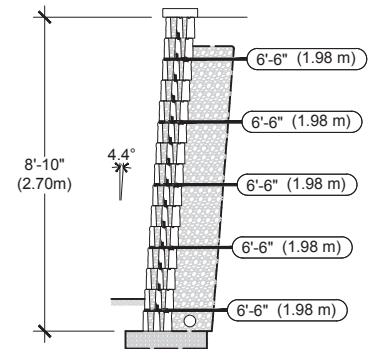
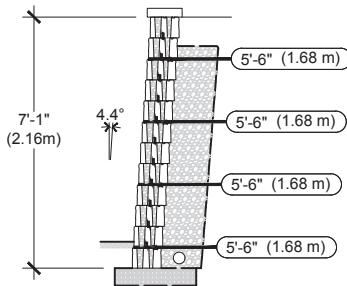
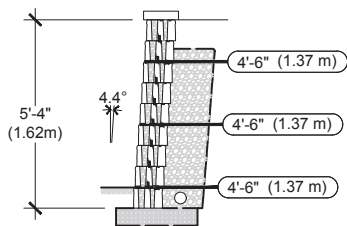

- The information contained in the design charts is supplied for information purposes only and as such should only be used for preliminary designs.
- The height (H) of the wall is the total height from the leveling pad to the top of the wall not including the thickness of the cap.
- Soil parameters: reinforced soil ( $\phi = 34^\circ$ ,  $\gamma = 120$  pcf); retained soil ( $\phi = 34^\circ$ ,  $\gamma = 120$  pcf); foundation soil ( $\phi = 34^\circ$ ,  $\gamma = 120$  pcf)
- A qualified engineer should be consulted for the final design to be used for construction.
- The foundation soil must be able to support the wall system. The bearing capacity of the foundation soil, settlement, and global stability must be verified and validated by a qualified geotechnical engineer.
- The seismic analysis is not included.
- The design charts do not apply to tiered walls.
- The charts assume that the walls are constructed in accordance with Techo-Bloc specifications, good construction practice and an adequate drainage system.
- The geogrid layout has been optimized to satisfy the design requirements of the NCMA's Design Manual for Segmental Retaining Walls, 3rd Edition.
- The minimum burial depth must be 6 in (150 mm) or 10% of the exposed height, whichever is greater.
- Engineering judgement should be used when interpolating between heights.
- Techo-Bloc and its predecessors, successors, beneficiaries, employees, associates, administrators and insurers accepts no liability for the incorrect use of information contained in the design charts.
- For further information, please contact our technical service department.

# INSTALLATION GUIDE

## RETAINING WALLS - BRANDON 90 & 180 mm

The different modules of the Brandon retaining wall allow the installation of different block combinations.

Twelve combinations are shown as an example. Each combination is 41 1/2" (1055 mm) long and 10 5/8" (270 mm) high.

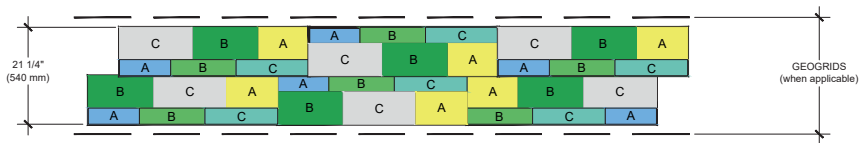
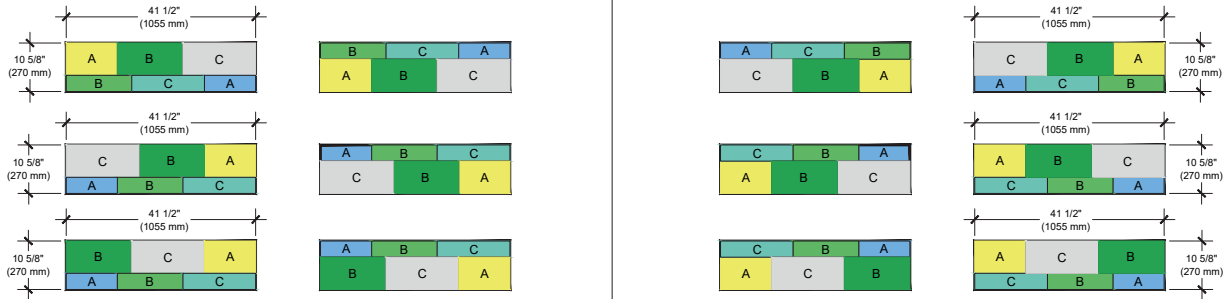

### NUMBER OF BLOCKS REQUIRED

#### BRANDON

33% of the surface - Brandon 90 mm

67% of the surface - Brandon 180 mm

### MODULE

	A	B	C
33% of the surface - Brandon 90 mm	6	6	6
67% of the surface - Brandon 180 mm	6	6	6

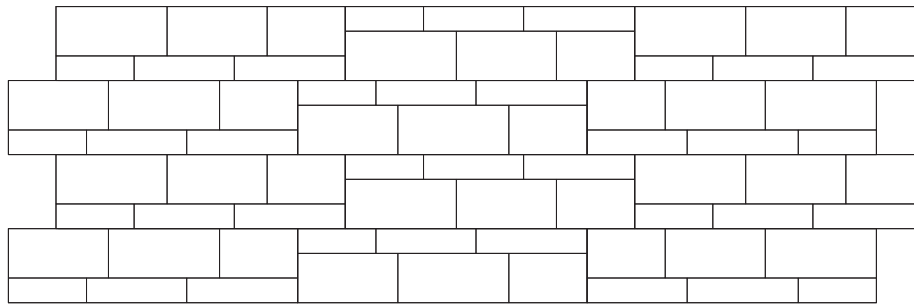

# INSTALLATION GUIDE

## FREESTANDING WALLS - BRANDON 90 & 180 mm

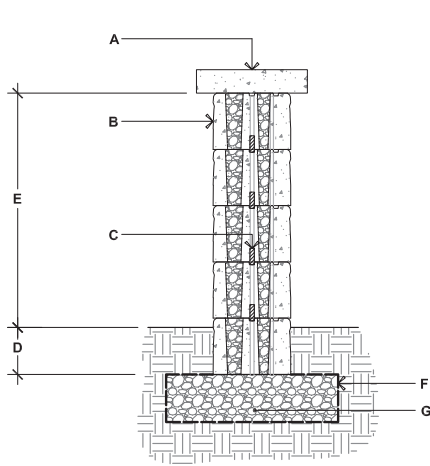

### BRANDON 90 mm & 180 mm

- A. TECHO-BLOC CAP UNIT SECURED TO UNIT BELOW WITH CONCRETE ADHESIVE
- B. BRANDON 90 mm AND 180 mm DOUBLE-SIDED WALL UNITS SECURE EACH ROW WITH CONCRETE ADHESIVE
- C. CONNECTOR
- D. EMBEDMENT DEPTH, 6" (150 mm) MIN.
- E. 29 7/16" (750 mm) MAX.
- F. GEOTEXTILE
- G. COMPACTED GRANULAR LEVELING PAD, 6" (150 mm) THICK MIN. THICKNESS ACCORDING TO PROJECT SPECIFIC CONDITIONS

## 90° CORNER OF A DOUBLE-SIDED WALL

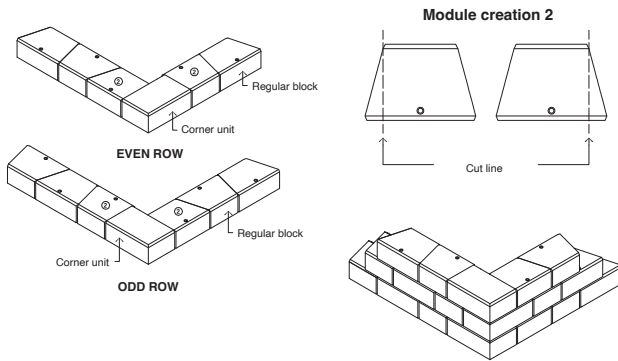

1. Alternate odd and even rows.
2. Stagger joints from one row to the next.
3. Glue all modules at each row with concrete adhesive.
4. Cavities, grooves and connectors are not illustrated to avoid overloading the image.

## DOUBLE-SIDED WALL - END OF A STRAIGHT WALL

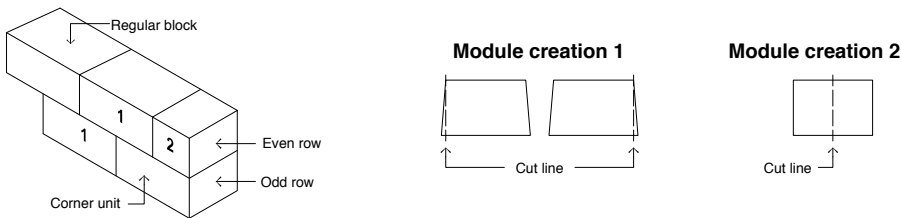

### GENERAL NOTES

1. Alternate odd and even rows.
2. Stagger joints from one row to the next.
3. Glue all modules at each row with concrete adhesive.
4. Cavities, grooves and connectors are not illustrated to avoid overloading the image.

# INSTALLATION GUIDE

## DOUBLE-SIDED WALL RADIUS - BRANDON 90 & 180 mm

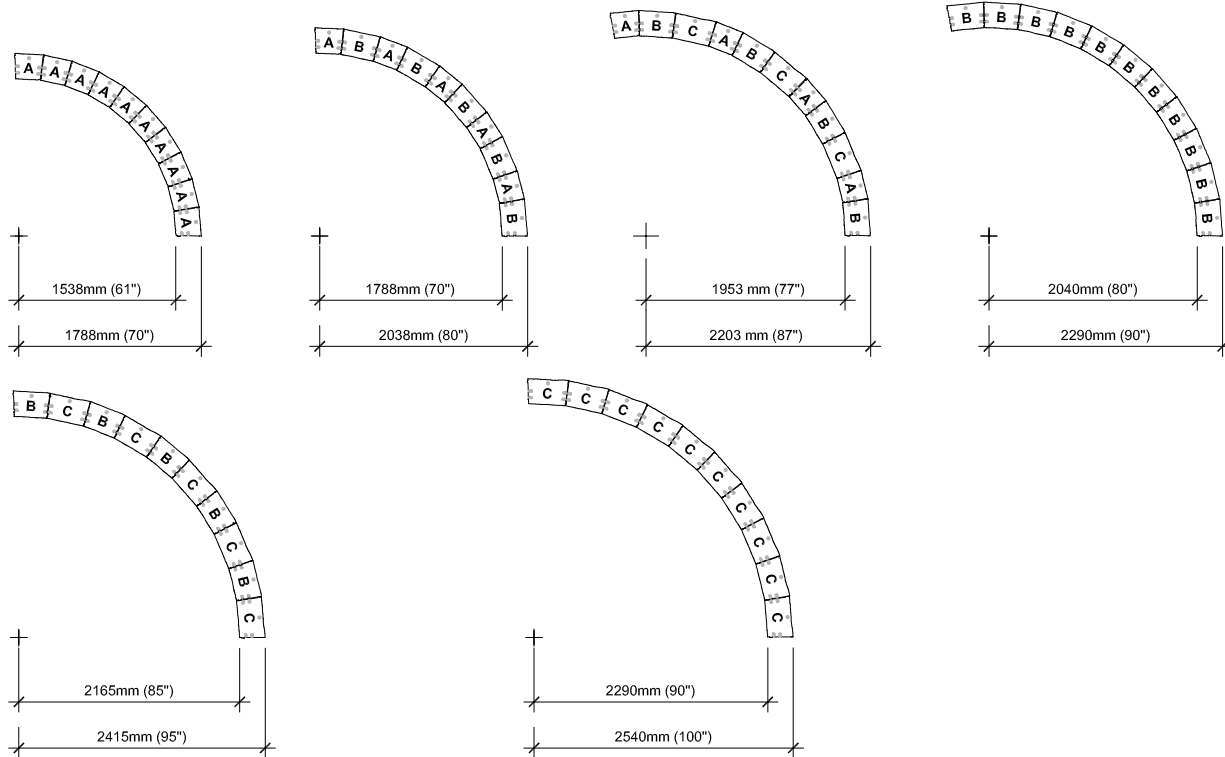

It is the user's responsibility to verify for the quantity of materials required.

## STEPS

### BRANDON 90 mm

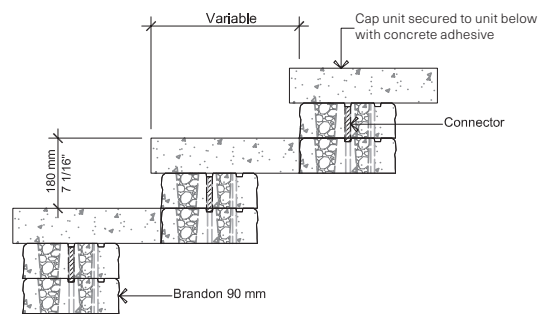

### BRANDON 180 mm

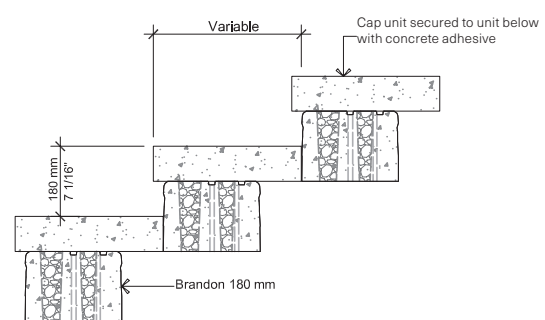

For all possible combinations of pillars and caps, please refer to the correspondence table on page 145

Check with your local Building Codes to determine any restrictions or guidelines regarding the dimensions of steps (including riser height and step tread) as well as handrail specifications.

PLEASE REFER TO P.4 FOR THE CORRECT USE AND LIMITATIONS OF PROVIDED TECHNICAL INFORMATION.

# INSTALLATION GUIDE

## PILLARS - BRANDON 90 & 180 mm

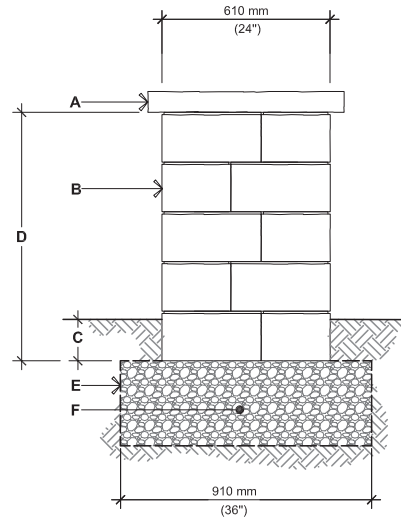
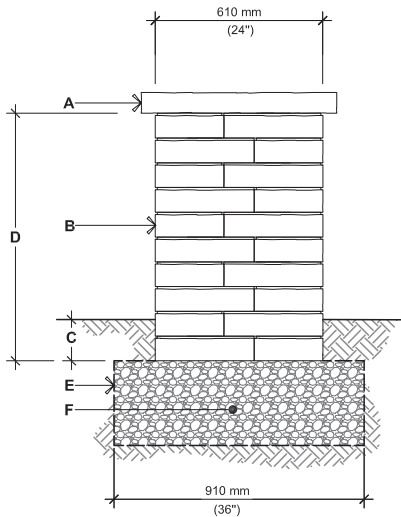

### BRANDON 90 mm

- A. PILLAR CAP UNIT, SECURE TO UNITS BELOW WITH CONCRETE ADHESIVE
- B. BRANDON 90 mm PILLAR UNIT SECURE EACH ROW WITH CONCRETE ADHESIVE
- C. EMBEDMENT DEPTH: 150 mm (6") MIN.
- D. 900 mm (35 7/16"), HEIGHT PER PALLET 1 080 mm (42 1/2"), MAXIMUM HEIGHT
- E. GEOTEXTILE
- F. COMPACTED GRANULAR BASE 150 mm (6") THICK MIN. THICKNESS ACCORDING TO PROJECT SPECIFIC CONDITIONS

### BRANDON 180 mm

- A. PILLAR CAP UNIT, SECURE TO UNITS BELOW WITH CONCRETE ADHESIVE
- B. BRANDON 180 mm PILLAR UNIT SECURE EACH ROW WITH CONCRETE ADHESIVE
- C. EMBEDMENT DEPTH: 150 mm (6") MIN.
- D. 900 mm (35 7/16"), HEIGHT PER PALLET 1 080 mm (42 1/2"), MAXIMUM HEIGHT
- E. GEOTEXTILE
- F. COMPACTED GRANULAR BASE 150 mm (6") THICK MIN. THICKNESS ACCORDING TO PROJECT SPECIFIC CONDITIONS

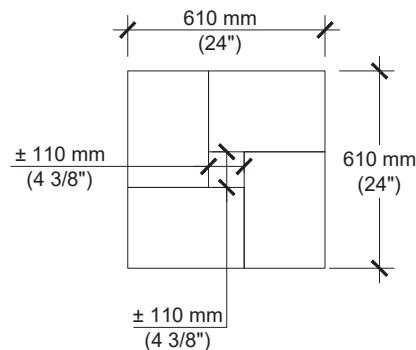

For all possible combinations of pillars and caps, please refer to the correspondence table on page 145

# INSTALLATION GUIDE

## PILLARS - BRANDON 90 & 180 mm

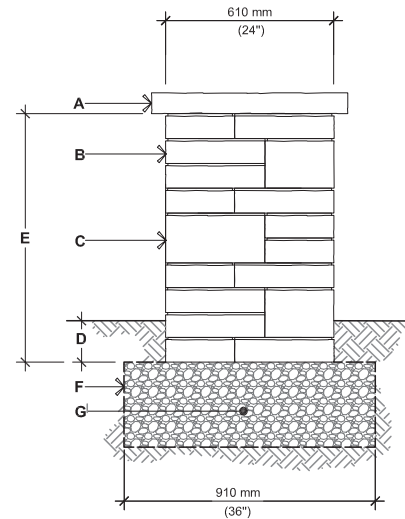
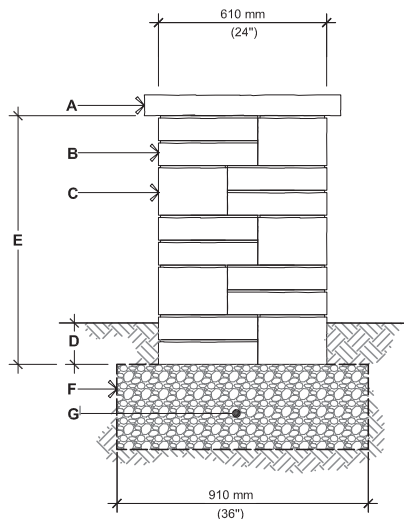

**BRANDON 90 mm & 180 mm**  
OPTION A

**BRANDON 90 mm & 180 mm**  
OPTION B

- A.** PILLAR CAP UNIT, SECURE TO UNITS BELOW WITH CONCRETE ADHESIVE
- B.** BRANDON 90 mm PILLAR UNIT SECURE EACH ROW WITH CONCRETE ADHESIVE
- C.** BRANDON 180 mm PILLAR UNIT SECURE EACH ROW WITH CONCRETE ADHESIVE
- D.** EMBEDMENT DEPTH: 150 mm (6") MIN.
- E.** 900 mm (35 7/8"), 1 080 mm (42 1/2"), MAXIMUM HEIGHT
- F.** GEOTEXTILE
- G.** COMPACTED GRANULAR BASE 150 mm (6") THICK MIN. THICKNESS ACCORDING TO PROJECT SPECIFIC CONDITIONS

- A.** PILLAR CAP UNIT, SECURE TO UNITS BELOW WITH CONCRETE ADHESIVE
- B.** BRANDON 90 mm PILLAR UNIT SECURE EACH ROW WITH CONCRETE ADHESIVE
- C.** BRANDON 180 mm PILLAR UNIT SECURE EACH ROW WITH CONCRETE ADHESIVE
- D.** EMBEDMENT DEPTH: 150 mm (6") MIN.
- E.** 900 mm (35 7/8"), 1 080 mm (42 1/2"), MAXIMUM HEIGHT
- F.** GEOTEXTILE
- G.** COMPACTED GRANULAR BASE 150 mm (6") THICK MIN. THICKNESS ACCORDING TO PROJECT SPECIFIC CONDITIONS

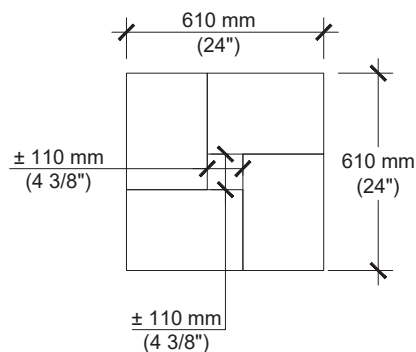

For all possible combinations of pillars and caps, please refer to the correspondence table on page 145

# INSTALLATION GUIDE

## GRILL ISLAND - BRANDON 90 & 180 mm

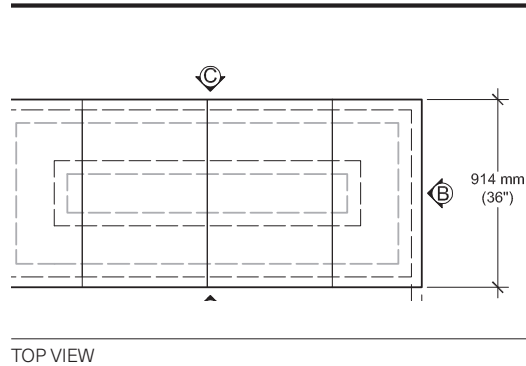
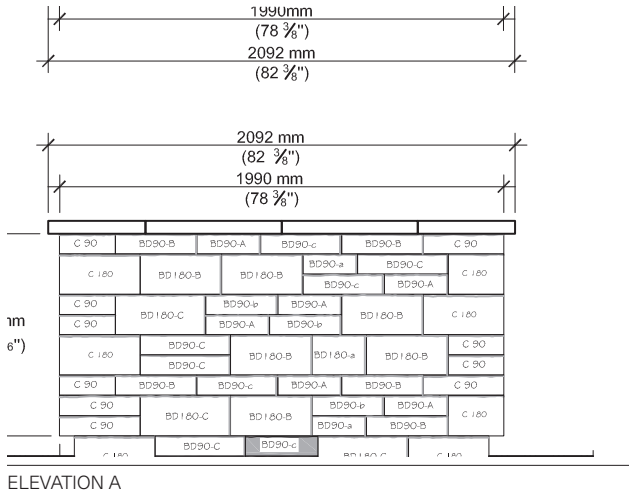

- A. YORK COUNTER TOP 24" x 36" x 2 1/4"
- B. BRANDON 90 mm UNIT (A, B OR C) – LONG FACE EXPOSED (SHOWN WITH UPPERCASE LETTER)
- C. BRANDON 90 mm UNIT (A, B OR C) – SHORT FACE EXPOSED (SHOWN WITH LOWERCASE LETTER)
- D. BRANDON 180 mm UNIT (A, B OR C) – LONG FACE EXPOSED (SHOWN WITH UPPERCASE LETTER)
- E. BRANDON 180 mm UNIT (A, B OR C) – SHORT FACE EXPOSED (SHOWN WITH LOWERCASE LETTER)
- F. BRANDON 90 mm PILLAR UNIT
- G. BRANDON 180 mm PILLAR UNIT
- H. BRANDON UNIT CUT ON FIELD
- I. CAST IN PLACE CONCRETE SLAB 4350 psi (30 MPa), 5" (125 mm) THICK
- J. 4X4-4/4 (102x102-MW25.8xMW25.8) WELDED WIRE MESH AND/OR REBAR AS PER SITE CONDITIONS
- K. 12" (300 mm) DIA. CONCRETE PILLAR, AS PER LOCAL CODE
- L. 3/4" (20 mm) CLEAN STONE 6" (150 mm) THICK MIN. AS PER SITE CONDITIONS
- M. NATURAL SOIL OR COMPACTED BACKFILL
- N. GEOTEXTILE

### QUANTITY OF MATERIALS REQUIRED

- York Counter top 24" x 36" x 2 1/4": **4**
- Brandon 90 mm unit: **20 A, 20 B, 18 C**
- Brandon 180 mm unit: **10 A, 10 B, 9 C**
- Brandon 90 mm Pillar unit: **18**
- Brandon 180 mm Pillar unit: **15**

**NOTE:** Appliances and utilities may vary for each project and are not shown on this drawing. This drawing is shown for inspiration only and surplus or shortage of materials may result. It is the user's responsibility to verify for the quantity of materials required. Secure the blocks using a heat resistant concrete adhesive. The installer must ensure that the installation and use of the grill island comply with local regulations and code requirements. Concrete pillars extending to frost line may be required as per local code. Check your local building code before installing.

# INSTALLATION GUIDE

## GRILL ISLAND - BRANDON 90 & 180 mm - Cont'd

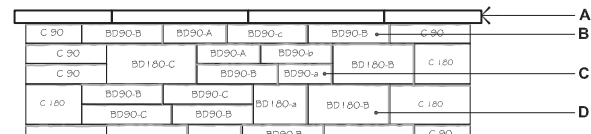
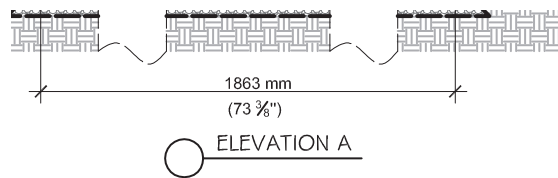

ELEVATION C

- A. YORK COUNTER TOP 24" x 36" x 2 1/4"
- B. BRANDON 90 mm UNIT (A, B OR C) – LONG FACE EXPOSED (SHOWN WITH UPPERCASE LETTER)
- C. BRANDON 90 mm UNIT (A, B OR C) – SHORT FACE EXPOSED (SHOWN WITH LOWERCASE LETTER)
- D. BRANDON 180 mm UNIT (A, B OR C) – LONG FACE EXPOSED (SHOWN WITH UPPERCASE LETTER)
- E. BRANDON 180 mm UNIT (A, B OR C) – SHORT FACE EXPOSED (SHOWN WITH LOWERCASE LETTER)
- F. BRANDON 90 mm PILLAR UNIT
- G. BRANDON 180 mm PILLAR UNIT
- H. BRANDON UNIT CUT ON FIELD
- I. CAST IN PLACE CONCRETE SLAB 4350 psi (30 MPa), 5" (125 mm) THICK
- J. 4X4-4/4 (102x102-MW25.8xMW25.8) WELDED WIRE MESH AND/OR REBAR AS PER SITE CONDITIONS
- K. 12" (300 mm) DIA. CONCRETE PILLAR, AS PER LOCAL CODE
- L. 3/4" (20 mm) CLEAN STONE 6" (150 mm) THICK MIN. AS PER SITE CONDITIONS
- M. NATURAL SOIL OR COMPACTED BACKFILL
- N. GEOTEXTILE

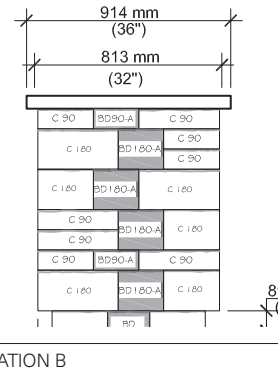

ELEVATION B

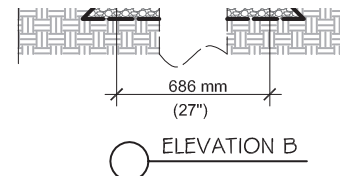

ELEVATION D

### QUANTITY OF MATERIALS REQUIRED

- York Counter top 24" x 36" x 2 1/4": **4**
- Brandon 90 mm unit: **20 A, 20 B, 18 C**
- Brandon 180 mm unit: **10 A, 10 B, 9 C**
- Brandon 90 mm Pillar unit: **18**
- Brandon 180 mm Pillar unit: **15**

**NOTE:** Appliances and utilities may vary for each project and are not shown on this drawing. This drawing is shown for inspiration only and surplus or shortage of materials may result. It is the user's responsibility to verify for the quantity of materials required. Secure the blocks using a heat resistant concrete adhesive. The installer must ensure that the installation and use of the grill island comply with local regulations and code requirements. Concrete pillars extending to frost line may be required as per local code. Check your local building code before installing.



D

## FASCIA wall collection

**DESCRIPTION:** Base and Structural block single-sided & double-sided **TEXTURE:** Smooth

### SINGLE-SIDED

#### Specifications per pallet



96 units / pallet

	Imperial	Metric
Product dimension (L x D x H)	7 7/8 x 9 1/4 x 5 7/8	200 x 235 x 150
Cubing	96 units	96 units
	31.00 ft <sup>2</sup>	2.88 m <sup>2</sup>
	62.99 lin. ft	19.20 lin. m
Approx. Weight	2 612 lbs	1 185 kg
Number of rows	4	
Coverage per row	7.75 ft <sup>2</sup>	0.72 m <sup>2</sup>
Linear coverage per row	15.75 lin. ft	4.80 lin. m

### Pallet Overview - single-sided

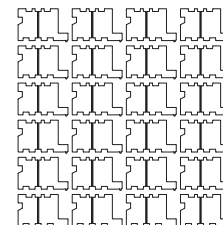

### DOUBLE-SIDED

#### Specifications per pallet

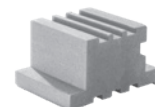

72 units / pallet

	Imperial	Metric
Product dimension (L x D x H)	7 7/8 x 11 1/6 x 5 7/8	200 x 281 x 150
Cubing	72 units	72 units
	23.25 ft <sup>2</sup>	2.16 m <sup>2</sup>
	47.24 lin. ft	14.40 lin. m
Approx. Weight	2 138 lbs	970 kg
Number of rows	4	
Coverage per row	5.81 ft <sup>2</sup>	0.54 m <sup>2</sup>
Linear coverage per row	11.81 lin. ft	3.60 lin. m

### Pallet Overview - double-sided

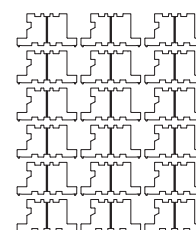

### BASE

#### Specifications per pallet

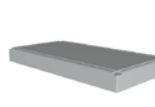

66 units / pallet

	Imperial	Metric
Product dimension (L x D x H)	23 5/8 x 12 x 2 3/8	600 x 305 x 60
Cubing	66 units	66 units
	25.58 ft <sup>2</sup>	2.38 m <sup>2</sup>
	129.92 lin. ft	39.60 lin. m
Approx. Weight	3 701 lbs	1 679 kg
Number of rows	11	
Coverage per row	2.33 ft <sup>2</sup>	0.22 m <sup>2</sup>
Linear coverage per row	11.81 lin. ft	3.60 lin. m

### Pallet Overview - base

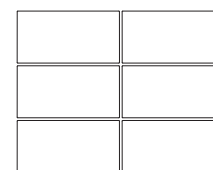

The top of Fascia Panels shall not be left exposed, they must be stabilized with a structural block on top or glued to the cap.

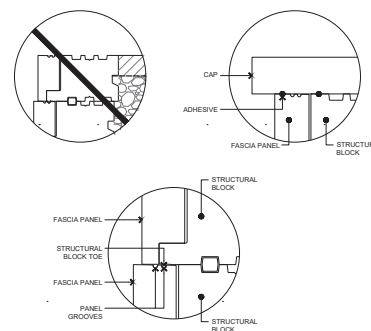

## NOTES

See page 6 for icons description.

### COMPATIBLE CAPS

See page 145 for product compatibility..

See page 146 to 161 for more technical information.



## ICONIC Fascia wall collection

DESCRIPTION: Fascia Panel & Corner TEXTURE: Klean-Bloc Slate

### Pallet Overview- panels

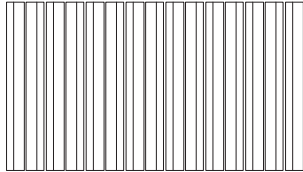

### Pallet Overview- corners

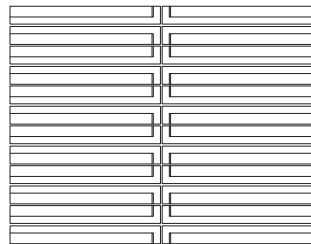

Klean-Bloc Natural Stone  
Rock Garden Brown

Klean-Bloc Natural Stone  
Victoria

Klean-Bloc Natural Stone  
Riviera

Klean-Bloc Natural Stone  
Onyx Black

### FASCIA

#### Specifications per pallet



42 units / pallet

	Imperial	Metric
Product dimension (L x D x H)	26 x 2 3/4 x 5 7/8	660 x 70 x 150
Cubing	42 units	42 units
	44.75 ft <sup>2</sup>	4.16 m <sup>2</sup>
	90.94 lin. ft	27.72 lin. m
Approx. Weight	1 250 lbs	567 kg
Number of rows	7	
Coverage per row	6.39 ft <sup>2</sup>	0.60 m <sup>2</sup>
Linear coverage per row	13.03 lin. ft	3.96 lin. m

### CORNER

#### Specifications per pallet



Left unit  
12 units / pallet



Right unit  
12 units / pallet

	Imperial	Metric
Product dimension (L x D x H) <b>A</b>	23 1/4 x 2 3/4 x 5 7/8	590 x 70 x 150
Product dimension (L x D x H) <b>B</b>	23 1/4 x 2 3/4 x 5 7/8	590 x 70 x 150
Cubing	24 units	24 units
Approx. Weight	700 lbs	318 kg
Number of rows	4	
Pillar height	35 7/16 in	900 mm

The top of Fascia Panels shall not be left exposed, they must be stabilized with a structural block on top or glued to the cap.

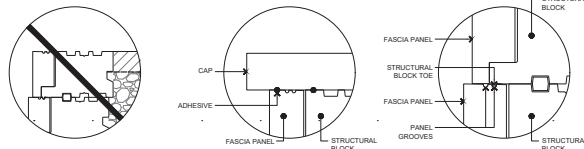

### NOTES

See page 6 for icons description.

#### COMPATIBLE CAPS

See page 145 for product compatibility.

See page 146 to 161 for more technical information.

Fascia Panels require single-sided structural blocks (retaining wall application) or double-sided structural blocks (freestanding walls). Sold Separately.



## ROSEMONT Fascia wall collection

**DESCRIPTION:** Fascia Panel & Corner **TEXTURE:** Klean-Bloc Slate

### FASCIA

#### Specifications per pallet

	Imperial	Metric
 Product dimension (L x D x H)	26 x 2 3/4 x 5 7/8	660 x 70 x 150
42 units / pallet	42 units	42 units
Cubing	44.75 ft <sup>2</sup>	4.16 m <sup>2</sup>
	90.94 lin. ft	27.72 lin. m
Approx. Weight	1 240 lbs	562 kg
Number of rows	7	
Coverage per row	6.39 ft <sup>2</sup>	0.60 m <sup>2</sup>
Linear coverage per row	13.03 lin. ft	3.96 lin. m

### CORNER

#### Specifications per pallet

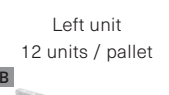
	Imperial	Metric
 Product dimension (L x D x H) <b>A</b>	23 1/4 x 2 3/4 x 5 7/8	590 x 70 x 150
 Product dimension (L x D x H) <b>B</b>	23 1/4 x 2 3/4 x 5 7/8	590 x 70 x 150
Cubing	24 units	24 units
Approx. Weight	660 lbs	299 kg
Number of rows	4	
Pillar height	35 7/16 in	900 mm

Left unit  
12 units / pallet

Right unit  
12 units / pallet

#### Pallet Overview - panels

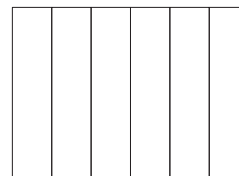

#### Pallet Overview - corners

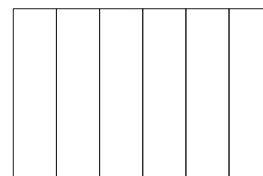

The top of Fascia Panels shall not be left exposed, they must be stabilized with a structural block on top or glued to the cap.

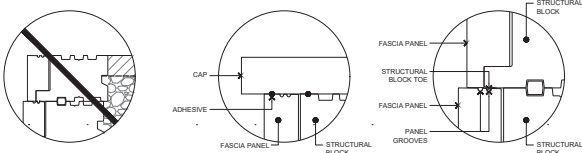

Rock Garden Brown

Klean-Bloc  
Slate



Riviera

Klean-Bloc  
Slate



Azzurro

Klean-Bloc  
Slate



## NOTES

See page 6 for icons description.

### COMPATIBLE CAPS

See page 145 for product compatibility.

See page 146 to 161 for more technical information.

Fascia Panels require single-sided structural blocks (retaining wall application) or double-sided structural blocks (freestanding walls).  
Sold Separately.

# INSTALLATION GUIDE

## FREESTANDING WALL

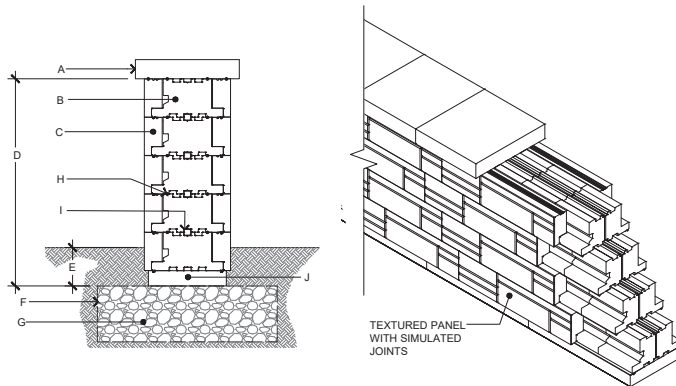

- A. TECO-BLOC CAP UNIT SECURED TO CORE AND PANEL BELOW WITH CONCRETE ADHESIVE
- B. STRUCTURAL BLOCK DOUBLE-SIDED UNIT
- C. PANEL UNIT
- D. 29 1/2" (750 mm) MAX.
- E. EMBEDMENT DEPTH 6" (150 mm) MIN.
- F. GEOTEXTILE
- G. COMPACTED GRANULAR BASE 6" (150 mm) MIN. THICKNESS ACCORDING TO PROJECT SPECIFICATIONS
- H. CONCRETE ADHESIVE
- I. HDPE HORIZONTAL KEY
- J. BASE UNIT

## FREESTANDING WALL - 90° CORNER

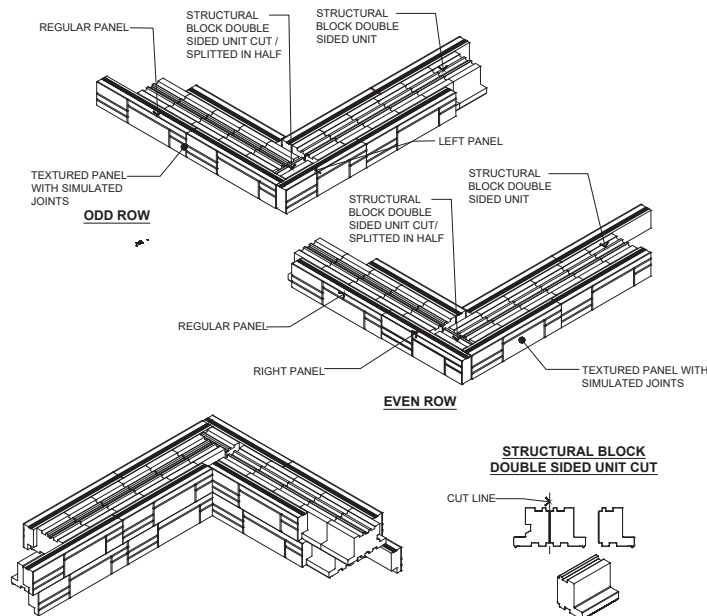

1. ALTERNATE ODD AND EVEN ROWS.
2. STAGGER STRUCTURAL BLOCKS JOINTS FROM ONE ROW TO THE NEXT.
3. GLUE ALL STRUCTURAL BLOCKS AT EACH ROW WITH CONCRETE ADHESIVE.
4. APPLY CONCRETE ADHESIVE ON TOP OF UPPERMOST PANEL UNITS TO FIX CAP UNITS.
5. STRUCTURAL BLOCK DOUBLE SIDED UNIT CUT / SPLITTED IN HALF MUST ALWAYS BE PRESENT AT THE CORNER OF THE WALL.

**NOTE:**

The top of Fascia Panels shall not be left exposed, they must be stabilized with a structural block on top or glued to the cap.

## GRAVITY RETAINING WALL

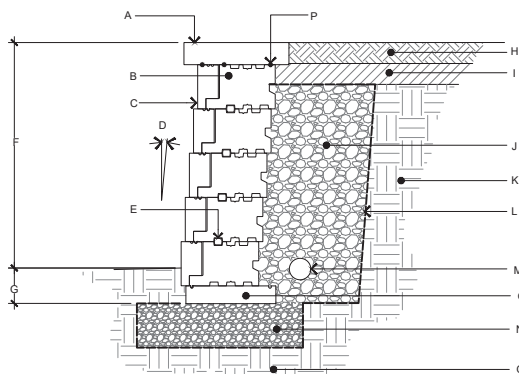

- A. TECO-BLOC CAP UNIT SECURED TO UNIT BELOW WITH CONCRETE ADHESIVE
- B. STRUCTURAL BLOCK SINGLE SIDED UNIT
- C. PANEL UNIT
- D. WALL INCLINATION (5.3°)
- E. HDPE HORIZONTAL KEY
- F. EXPOSED HEIGHT
- G. EMBEDMENT DEPTH
- H. TOP SOIL
- I. LOW PERMEABILITY SOIL
- J. 3/4" (20 mm) CLEAN STONE 14" (350mm) THICK MIN.
- K. RETAINED SOIL
- L. GEOTEXTILE
- M. PERFORATED DRAIN
- N. LEVELING PAD
- O. FOUNDATION SOIL
- P. CONCRETE ADHESIVE
- Q. BASE UNIT

# INSTALLATION GUIDE

## FREESTANDING END OF A STRAIGHT WALL (OPTION 1)

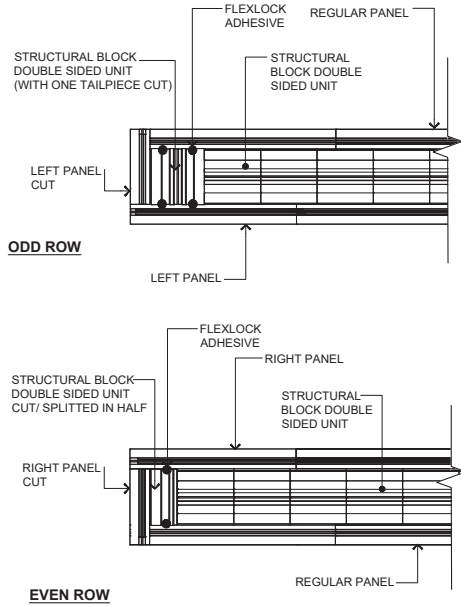

- NOTES:
1. ALTERNATE ODD AND EVEN ROWS.
  2. STAGGER STRUCTURAL BLOCKS JOINTS FROM ONE ROW TO THE NEXT.
  3. GLUE ALL STRUCTURAL BLOCKS AT EACH ROW WITH FLEXLOCK ADHESIVE.
  4. APPLY FLEXLOCK ADHESIVE ON TOP OF UPPERMOST PANEL UNITS TO FIX CAP UNITS.

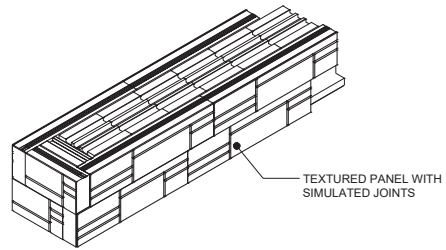

**NOTE:**  
The top of Fascia Panels shall not be left exposed, they must be stabilized with a structural block on top or glued to the cap.

## FREESTANDING END OF A STRAIGHT WALL (OPTION 2)

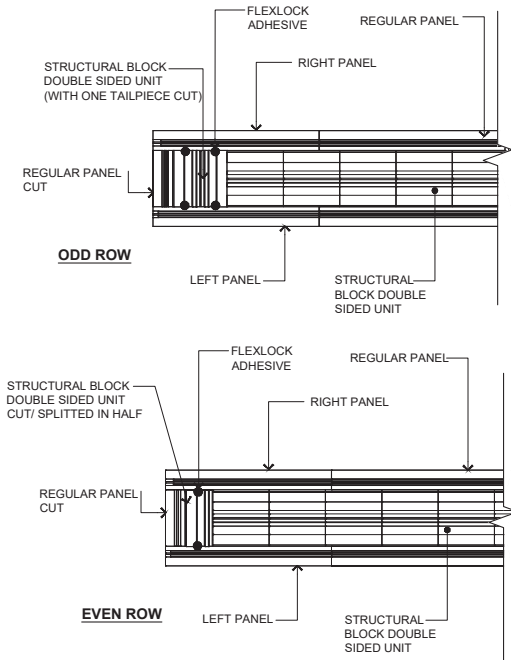

- NOTES:
1. ALTERNATE ODD AND EVEN ROWS.
  2. STAGGER STRUCTURAL BLOCKS JOINTS FROM ONE ROW TO THE NEXT.
  3. GLUE ALL STRUCTURAL BLOCKS AT EACH ROW WITH FLEXLOCK ADHESIVE.
  4. APPLY FLEXLOCK ADHESIVE ON TOP OF UPPERMOST PANEL UNITS TO FIX CAP UNITS.

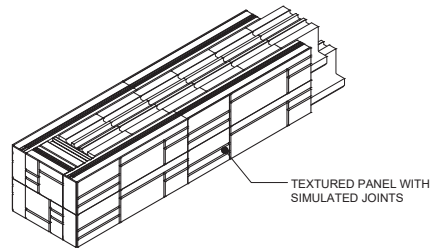

# INSTALLATION GUIDE

## PILLARS - FASCIA WALL COLLECTION

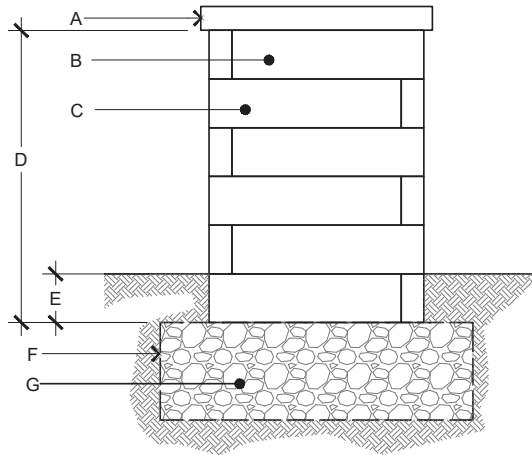

### STRUCTURAL BLOCK SINGLE SIDED UNIT CUT / SPLITTED IN HALF

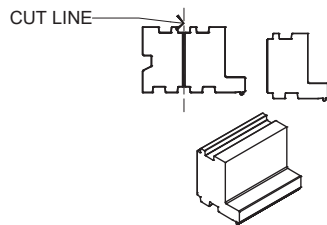

- A. PILLAR CAP UNIT SECURED TO CORE AND PANEL BELOW WITH CONCRETE ADHESIVE
- B. RIGHT PANEL
- C. LEFT PANEL
- D. 35 7/8" (900 mm) MAX HEIGHT
- E. EMBEDMENT DEPTH 6" (150 mm) MIN.
- F. GEOTEXTILE
- G. COMPACTED GRANULAR BASE 6" (150 mm) MIN. THICKNESS ACCORDING TO PROJECT SPECIFICATIONS.

#### NOTE:

The top of Fascia Panels shall not be left exposed, they must be stabilized with a structural block on top or glued to the cap

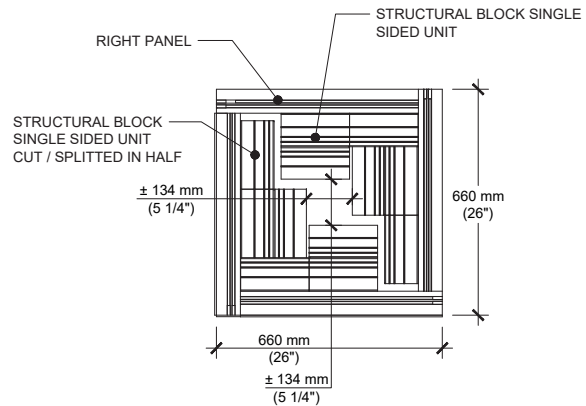

#### ODD ROW

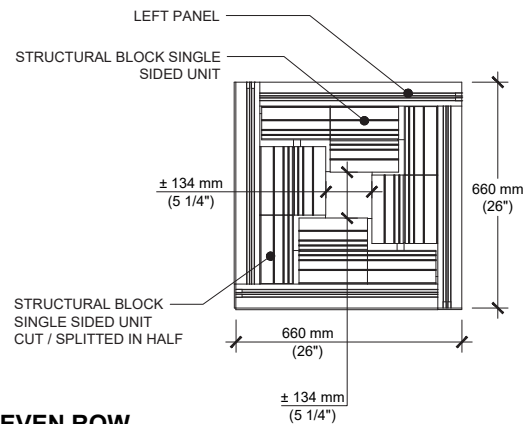

#### EVEN ROW

IIN.

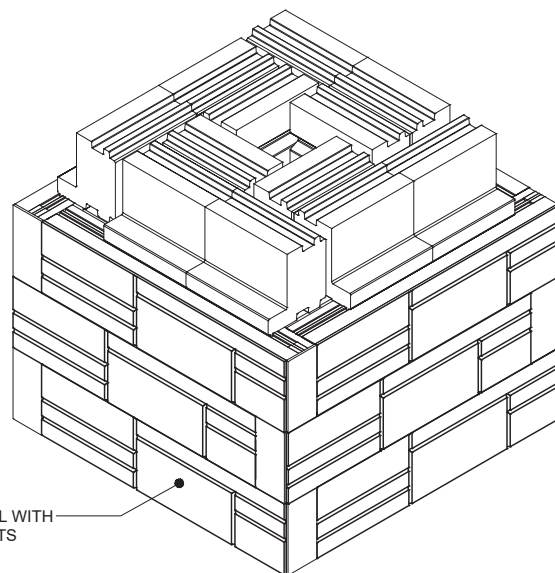

TEXTURED PANEL WITH  
SIMULATED JOINTS

For all possible combinations of pillars and caps, please refer to the correspondence table on page 145

# INSTALLATION GUIDE

## STEPS - FASCIA WALL COLLECTION

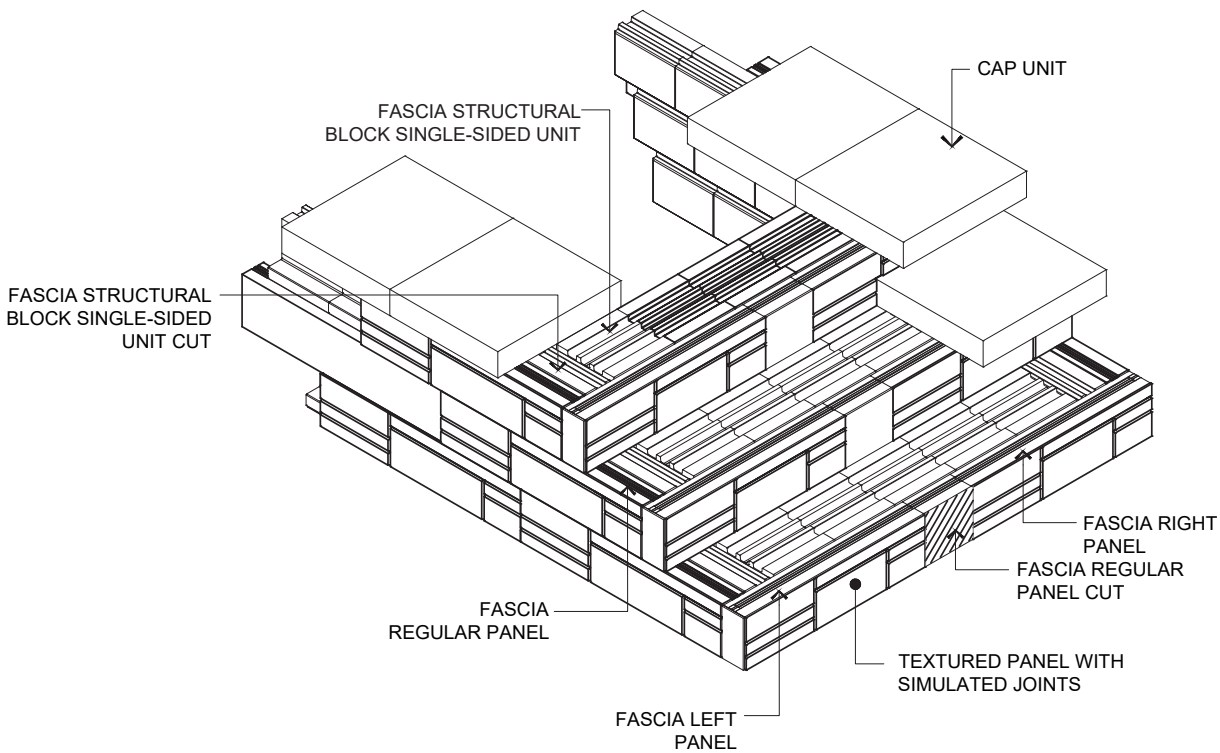
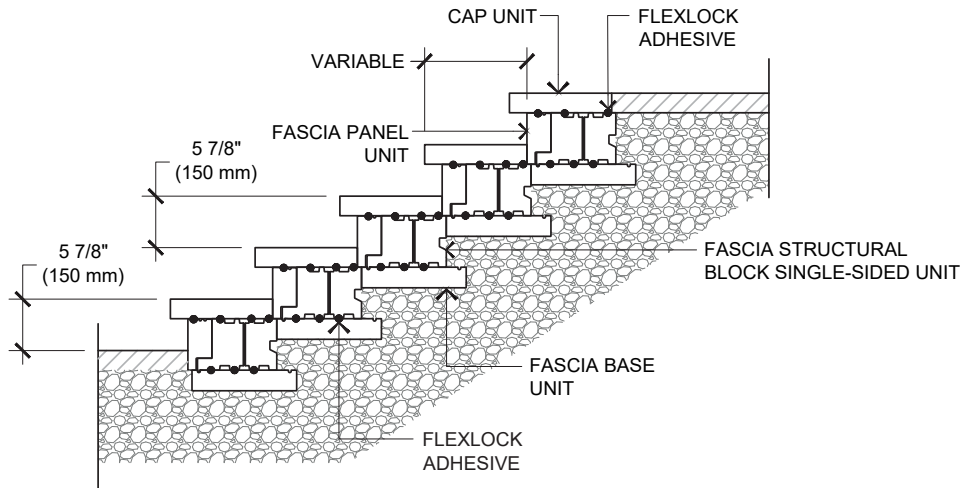

### NOTE:

The top of Fascia Panels shall not be left exposed, they must be stabilized with a structural block on top or glued to the cap

Check with your local Building Codes to determine any restrictions or guidelines regarding the dimensions of steps (including riser height and step tread) as well as handrail specifications.

D ❄️

**G-FORCE**

DESCRIPTION: Wall TEXTURE: Smooth

**Pallet Overview**

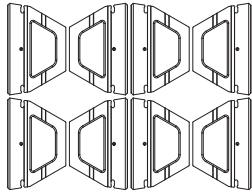

Smooth  
Chestnut Brown  
Smooth  
Champlain Grey  
Smooth  
Shale Grey

**Specifications per pallet**



32 units / pallet

	Imperial	Metric
Dimension Front (L x D x H)	18 x 11 7/16 x 8	457 x 290 x 203
Dimension Back (L x D x H)	8 5/8 x 11 7/16 x 8	219 x 290 x 203
Cubing	32.00 ft <sup>2</sup>	2.97 m <sup>2</sup>
	48 lin. ft	14.63 lin. m
Approx. Weight	2 477 lbs	1 124 kg
Number of rows	4	
Coverage per row	8.00 ft <sup>2</sup>	0.74 m <sup>2</sup>
Linear coverage per row	12.00 lin. ft	3.66 lin. m

**NOTES**

See page 6 for icons description.

**COMPATIBLE CAPS**

See page 145 for product compatibility.

G-Force block can be installed in a setback position only (inclined wall). The positioning of the HDPE key does not allow for a vertical installation.

Geogrid positioning: visit our website for geogrid design charts

See page 146 to 161 for more technical information.



D ❄️

## G-FORCE Corner unit

DESCRIPTION: Wall TEXTURE: Smooth

Specifications per pallet	Imperial	Metric
 16 units / pallet	Product dimension (L×D×H)	18 × 9 × 8
	Cubing	16 units
	Approx. Weight	1 654 lbs
Number of rows	2	

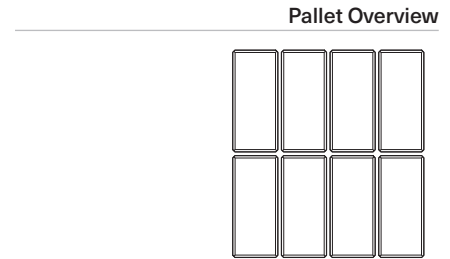

### NOTES

See page 6 for icons description.

#### COMPATIBLE CAPS

See page 145 for product compatibility.

See page 146 to 161 for more technical information.

CLEAN SAND/GRAVEL/ SAND AND GRAVEL MIXES ( $\phi=34^\circ$ ,  $\gamma = 120$  pcf)  
 GEOGRID: MIRAGRID 3XT BY TENCATE (RFd=1.10, RFcr=1.45, RFid=1.25, Cds=0.9, Ci=0.9)

**CASE N° 1 :**  
 No Surcharge  
 No Backslope  
 No Toe Slope

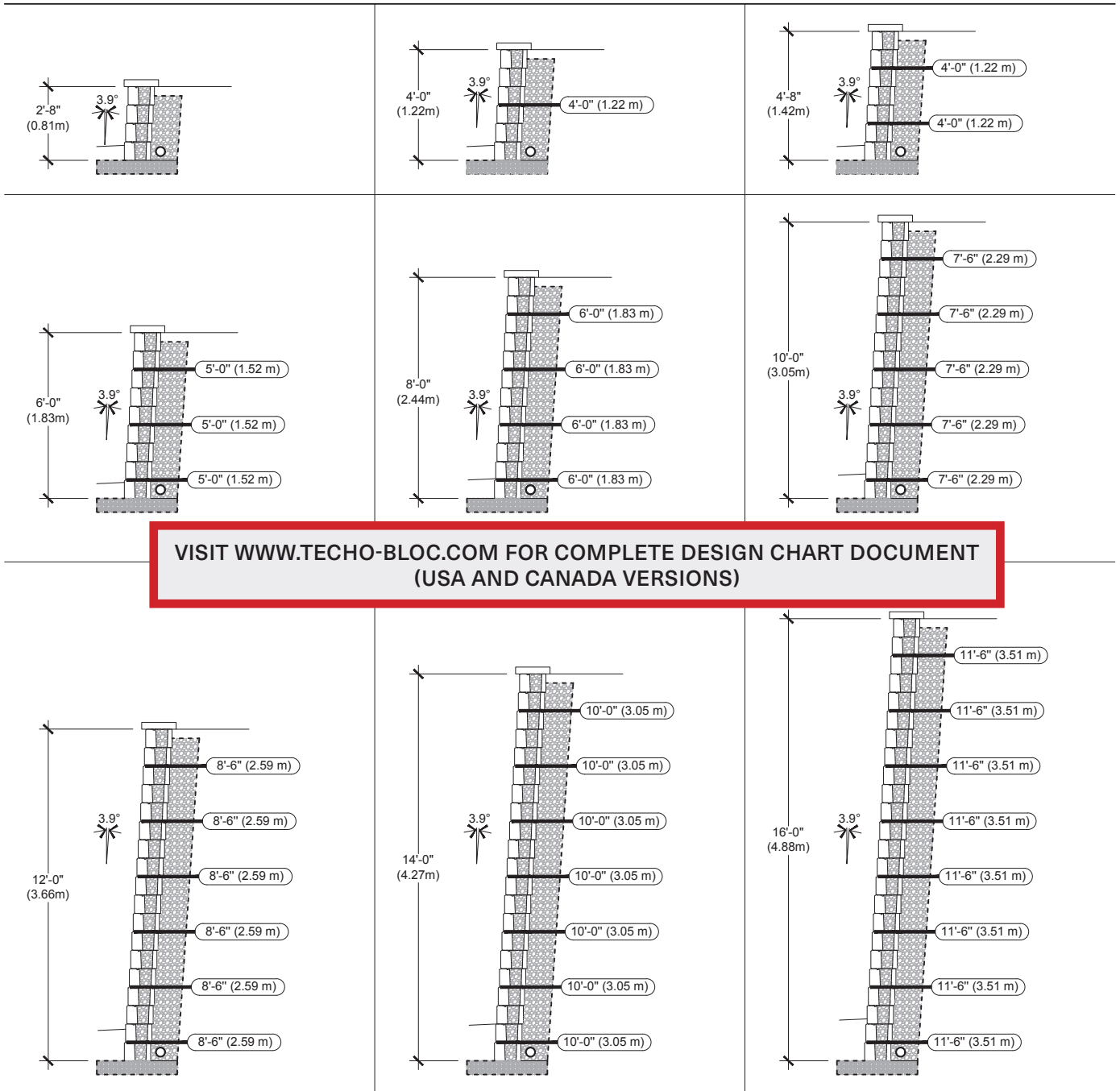

VISIT [WWW.TECHO-BLOC.COM](http://WWW.TECHO-BLOC.COM) FOR COMPLETE DESIGN CHART DOCUMENT  
 (USA AND CANADA VERSIONS)

1. The information contained in the design charts is supplied for information purposes only and as such should only be used for preliminary designs.
2. The height (H) of the wall is the total height from the leveling pad to the top of the wall not including the thickness of the cap.
3. Soil parameters: reinforced soil ( $\phi = 34^\circ$ ,  $\gamma = 120$  pcf); retained soil ( $\phi = 34^\circ$ ,  $\gamma = 120$  pcf); foundation soil ( $\phi = 34^\circ$ ,  $\gamma = 120$  pcf)
4. A qualified engineer should be consulted for the final design to be used for construction.
5. The foundation soil must be able to support the wall system. The bearing capacity of the foundation soil, settlement, and global stability must be verified and validated by a qualified geotechnical engineer.
6. The seismic analysis is not included.
7. The design charts do not apply to tiered walls.
8. The charts assume that the walls are constructed in accordance with Techo-Bloc specifications, good construction practice and an adequate drainage system.
9. The geogrid layout has been optimized to satisfy the design requirements of the NCMA's Design Manual for Segmental Retaining Walls, 3rd Edition.
10. The minimum burial depth must be 6 in (150 mm) or 10% of the exposed height, whichever is greater.
11. Engineering judgement should be used when interpolating between heights.
12. Techo-Bloc and its predecessors, successors, beneficiaries, employees, associates, administrators and insurers accepts no liability for the incorrect use of information contained in the design charts.
13. For further information, please contact our technical service department.

# INSTALLATION GUIDE

## GRAVITY AND REINFORCED WALLS - G-FORCE

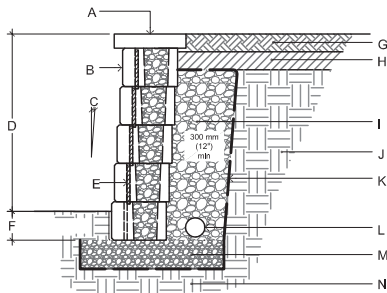

GRAVITY WALL DETAIL

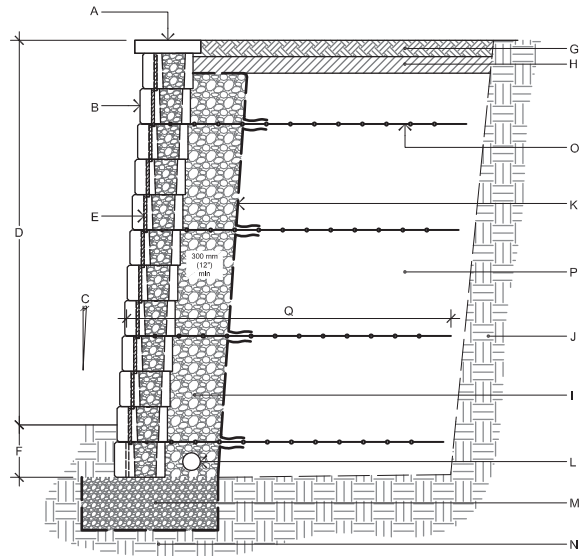

REINFORCED WALL DETAIL

- A. CAP FROM TECHO-BLOC
- B. G-FORCE BLOCK FROM TECHO-BLOC
- C. WALL INCLINATION (3.9°)
- D. EXPOSED HEIGHT
- E. HDPE VERTICAL KEY
- F. EMBEDMENT DEPTH
- G. TOP SOIL
- H. LOW PERMEABILITY SOIL
- I. ¾" (20 mm) CLEAN STONE

- J. RETAINED SOIL
- K. GEOTEXTILE
- L. PERFORATED DRAIN
- M. LEVELING PAD
- N. FOUNDATION SOIL
- O. GEOGRID
- P. REINFORCED SOIL
- Q. GEOGRID LENGTH

## STEPS - G-FORCE

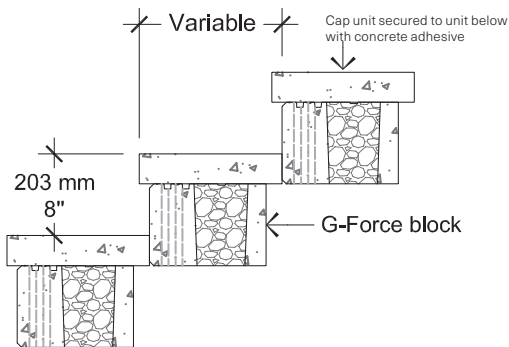

For all possible combinations of pillars and caps, please refer to the correspondence table on page 145

Check with your local Building Codes to determine any restrictions or guidelines regarding the dimensions of steps (including riser height and step tread) as well as handrail specifications.

# INSTALLATION GUIDE

## PILLARS - G-FORCE

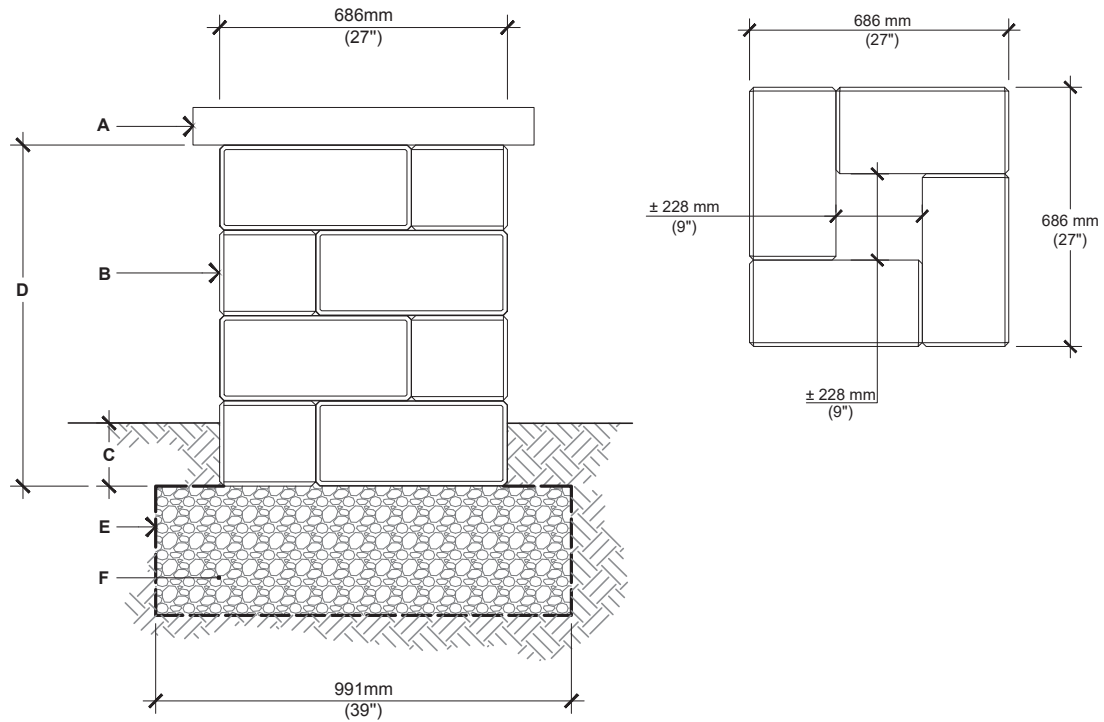

### G-FORCE PILLAR





- A.** PILLAR CAP UNIT  
(SECURE WITH CONCRETE ADHESIVE)
- B.** G-FORCE UNIT SECURE EACH ROW WITH  
CONCRETE ADHESIVE
- C.** EMBEDMENT 6" (150 mm) MIN.
- D.** 32" (813 mm) HEIGHT PER PALLET  
48" (1219 mm), MAX. HEIGHT
- E.** GEOTEXTILE
- F.** COMPACTED GRANULAR BASE 6"  
(150 mm THICK MIN. THICKNESS ACCORDING  
TO PROJECT SPECIFIC CONDITIONS)

For all possible combinations of pillars and caps, please refer to the correspondence table on page 145

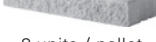

# GRAPHIX

**DESCRIPTION:** Wall double-sided **TEXTURE:** Smooth & Split face

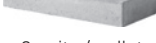
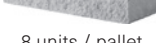
Specifications per pallet		Imperial	Metric
<b>1</b>	 8 units / pallet	Product dimension (L×D×H) <b>1</b> 20 × 9 1/16 × 2 15/16	508 × 230 × 75
		Product dimension (L×D×H) <b>2</b> 20 × 10 1/16 × 2 15/16	508 × 255 × 75
		Product dimension (L×D×H) <b>3</b> 20 × 11 × 2 15/16	508 × 280 × 75
<b>2</b>	 8 units / pallet	Product dimension (L×D×H) <b>4</b> 20 × 8 1/16 × 2 15/16	508 × 205 × 75
		Product dimension (L×D×H) <b>1A</b> 20 × 9 1/16 × 2 15/16	508 × 230 × 75
		Product dimension (L×D×H) <b>2A</b> 20 × 10 1/16 × 2 15/16	508 × 255 × 75
<b>3</b>	 8 units / pallet	Product dimension (L×D×H) <b>3A</b> 20 × 11 × 2 15/16	508 × 280 × 75
		Product dimension (L×D×H) <b>4A</b> 20 × 8 1/16 × 2 15/16	508 × 205 × 75
<b>4</b>	 8 units / pallet split on one side	Cubing	26.25 ft <sup>2</sup> / 2.44 m <sup>2</sup>
		107.67 lin. ft	32.51 m lin.
		Approx. Weight	2 773 lbs / 1 258 kg
		Number of rows	8
		Coverage per row	3.28 ft <sup>2</sup> / 0.30 m <sup>2</sup>
<b>1A</b>	 8 units / pallet Left corner unit	Lin. coverage per row	13.33 lin. ft / 4.06 lin. m
<b>2A</b>	 8 units / pallet Right corner unit		
<b>3A</b>	 8 units / pallet Left corner unit		
<b>4A</b>	 8 units / pallet Right corner unit, split on one side		

## Pallet Overview

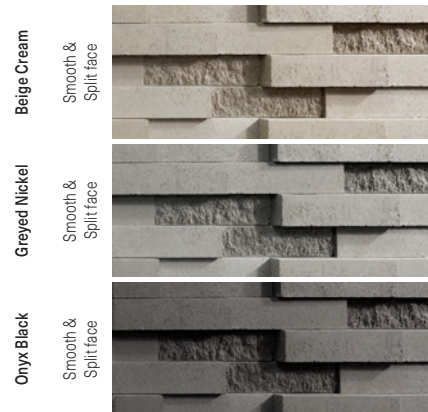
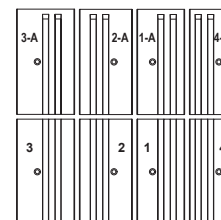

## NOTES

See page 6 for icons description.

### COMPATIBLE CAPS

See page 145 for product compatibility.

See page 146 to 161 for more technical information.

CLEAN SAND/GRAVEL/ SAND AND GRAVEL MIXES ( $\phi=34^\circ$ ,  $\gamma = 120$  pcf)  
GEOGRID: MIRAGRID 2XT BY TENCATE (RFd=1.10, RFcr=1.45, RFid=1.25, Cds=0.9, Ci=0.9)

**CASE N° 1 :**  
No Surcharge  
No Backslope  
No Toe Slope

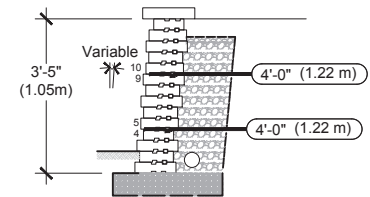
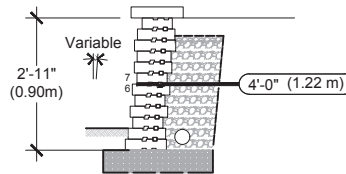
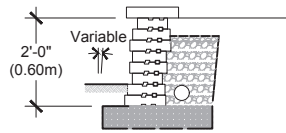

VISIT [WWW.TECHO-BLOC.COM](http://WWW.TECHO-BLOC.COM) FOR COMPLETE DESIGN CHART DOCUMENT  
(USA AND CANADA VERSIONS)

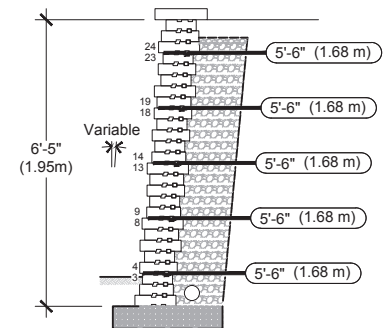
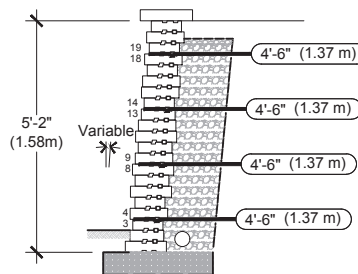
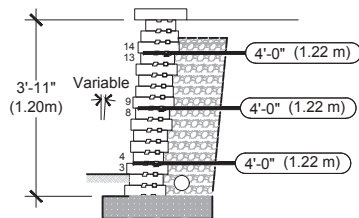

1. The information contained in the design charts is supplied for information purposes only and as such should only be used for preliminary designs.
2. The height (H) of the wall is the total height from the leveling pad to the top of the wall not including the thickness of the cap.
3. Soil parameters: reinforced soil ( $\phi = 34^\circ$ ,  $\gamma = 120$  pcf); retained soil ( $\phi = 34^\circ$ ,  $\gamma = 120$  pcf); foundation soil ( $\phi = 34^\circ$ ,  $\gamma = 120$  pcf)
4. A qualified engineer should be consulted for the final design to be used for construction.
5. The foundation soil must be able to support the wall system. The bearing capacity of the foundation soil, settlement, and global stability must be verified and validated by a qualified geotechnical engineer.
6. The seismic analysis is not included.
7. The design charts do not apply to tiered walls.
8. The charts assume that the walls are constructed in accordance with Techo-Bloc specifications, good construction practice and an adequate drainage system.
9. The geogrid layout has been optimized to satisfy the design requirements of the NCMA's Design Manual for Segmental Retaining Walls, 3rd Edition.
10. The minimum burial depth must be 6 in (150 mm) or 10% of the exposed height, whichever is greater.
11. Engineering judgement should be used when interpolating between heights.
12. Techo-Bloc and its predecessors, successors, beneficiaries, employees, associates, administrators and insurers accepts no liability for the incorrect use of information contained in the design charts.
13. For further information, please contact our technical service department.

# INSTALLATION GUIDE

## FREESTANDING WALLS - GRAPHIX

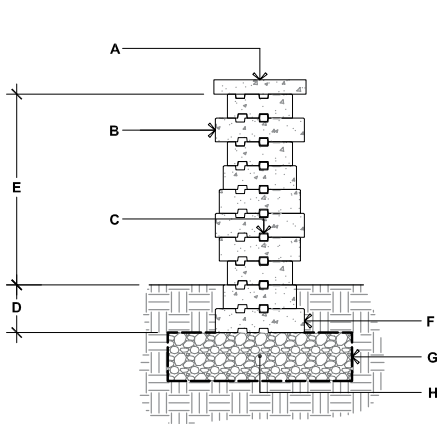

### GRAPHIX

- A. TECO-BLOC CAP UNIT SECURED TO UNIT BELOW WITH CONCRETE ADHESIVE
- B. GRAPHIX DOUBLE-SIDED WALL UNITS SECURE EACH ROW WITH CONCRETE ADHESIVE
- C. CONNECTOR
- D. EMBEDMENT DEPTH, 6" (150 mm) MIN.
- E. 23 1/2" (600 mm) MAX.
- F. FOR THE FIRST ROW, ALWAYS USE THE DEEPER GRAPHIX BLOCK
- G. GEOTEXTILE
- H. COMPACTED GRANULAR LEVELING PAD, 6" (150 mm) THICK MIN. THICKNESS ACCORDING TO PROJECT SPECIFIC CONDITIONS

## 90° CORNER OF A DOUBLE-SIDED WALL

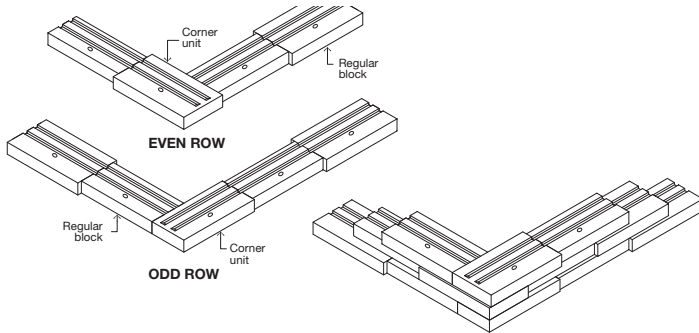

1. Alternate odd and even rows.
2. Stagger joints from one row to the next.
3. Glue all modules at each row with concrete adhesive.
4. Connectors are not illustrated to avoid overloading the image.
5. It is possible to alternate the blocks (1, 2, 3 or 4) in the same row to create different patterns. However, a corner block (1A, 2A, 3A or 4A) must always be present at the end of a row and must be alternated for each subsequent row.
6. At the corner, make sure to place the blocks so that the grooves of the block cannot be seen.

## DOUBLE-SIDED WALL - END OF A STRAIGHT WALL

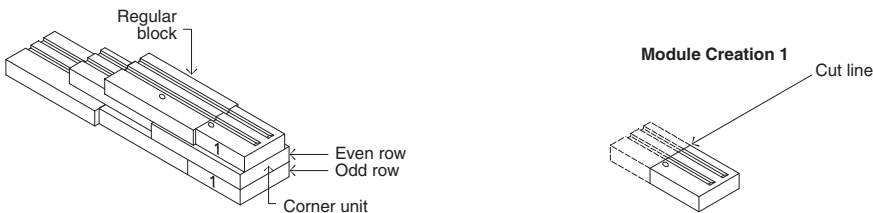

\* It is possible to alternate the blocks (1, 2, 3 or 4) in the same row to create different patterns. However, a corner block and a cut corner block (1A, 2A, 3A or 4A) must always be present at the end of a row and must be alternated for each subsequent row.

# INSTALLATION GUIDE

## PILLARS - GRAPHIX

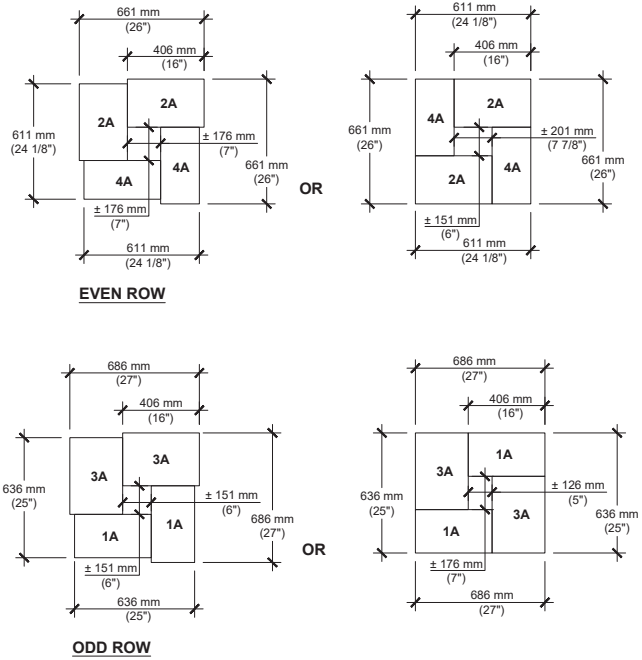
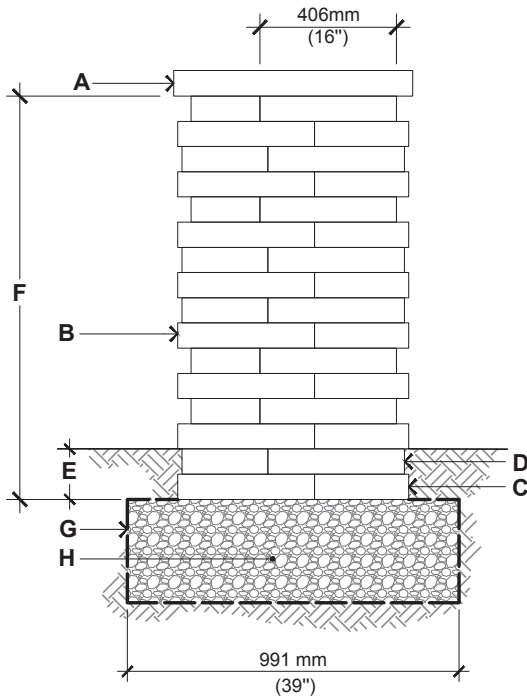

- NOTES:
- ALL UNITS MUST BE CUT ON FIELD
  - USE A CHISEL FOR DESIRED SPLITTED TEXTURE FACE

### GRAPHIX

- A.** PILLAR CAP UNIT (SECURE WITH CONCRETE ADHESIVE)
- B.** GRAPHIX CORNER UNIT  
SECURE EACH ROW WITH CONCRETE ADHESIVE  
CUT EACH BLOCK AT 16" (406 mm) FROM THE CORNER EDGE
- C.** USE THE BLOCKS 1A-3A FOR THE ODD ROWS
- D.** USE THE BLOCKS 2A-4A FOR THE EVEN ROWS
- E.** EMBEDMENT DEPTH 6" (150 mm) MIN.
- F.** 23 5/8" (600 mm) HEIGHT PER PALLET  
47 1/4" (1200 mm) MAXIMUM HEIGHT
- G.** GEOTEXTILE
- H.** COMPACTED GRANULAR BASE 6" (150 mm) THICK MIN.  
THICKNESS ACCORDING TO PROJECT SPECIFIC CONDITIONS

For all possible combinations of pillars and caps, please refer to the correspondence table on page 145





# MINI-CRETA 3" Architectural

DESCRIPTION: Wall double-sided TEXTURE: Split face with straight edged corners



PATENT  
CND 2,114,677  
US 5,528,873

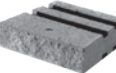
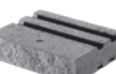

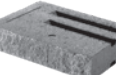
Specifications per pallet		Imperial	Metric
<b>A</b> 	Dimension Front (L x D x H) <b>A</b>	9 1/16 x 9 13/16 x 2 15/16	230 x 250 x 75
	Dimension Back (L x D x H) <b>A</b>	7 1/16 x 9 13/16 x 2 15/16	180 x 250 x 75
32 units / pallet	Dimension Front (L x D x H) <b>B</b>	11 13/16 x 9 13/16 x 2 15/16	300 x 250 x 75
	Dimension Back (L x D x H) <b>B</b>	9 13/16 x 9 13/16 x 2 15/16	250 x 250 x 75
<b>B</b> 	Dimension Front (L x D x H) <b>B*</b>	11 13/16 x 9 13/16 x 2 15/16	300 x 250 x 75
	Dimension Back (L x D x H) <b>B*</b>	11 13/16 x 9 13/16 x 2 15/16	300 x 250 x 75
24 units / pallet	Dimension Front (L x D x H) <b>C</b>	14 3/4 x 9 13/16 x 2 15/16	375 x 250 x 75
	Dimension Back (L x D x H) <b>C</b>	12 13/16 x 9 13/16 x 2 15/16	325 x 250 x 75
<b>B*</b> 	Dimension Front (L x D x H) <b>D</b>	14 3/4 x 9 13/16 x 2 15/16	375 x 250 x 75
	Dimension Back (L x D x H) <b>D</b>	13 3/4 x 9 13/16 x 2 15/16	350 x 250 x 75
8 units / pallet	Cubing	24 ft <sup>2</sup>	2.23 m <sup>2</sup>
	Approx. Weight	2 465 lbs	1 118 kg
<b>C</b> 	Minimum radius	7 ft	2.1 m
	Number of rows	8	
16 units / pallet	Coverage per row	3 ft <sup>2</sup>	0.28 m <sup>2</sup>
	Lin. coverage per row	11.88 lin. ft	3.62 lin. m
<b>D</b> 			

## Pallet Overview

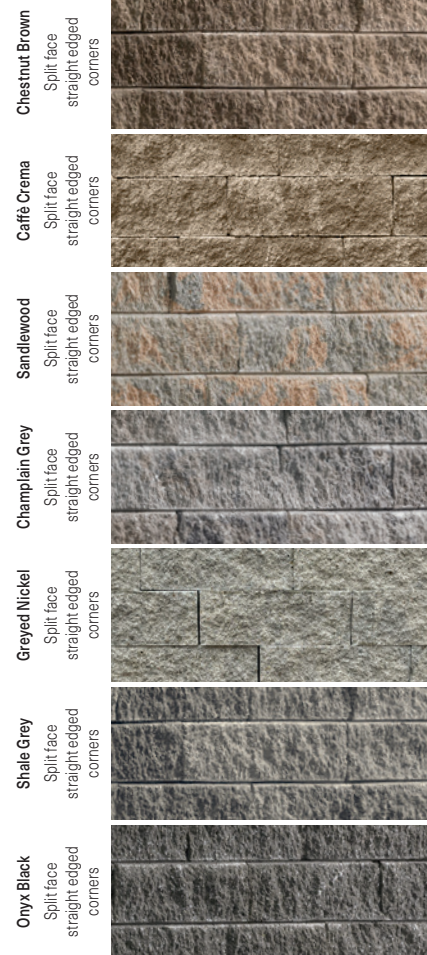
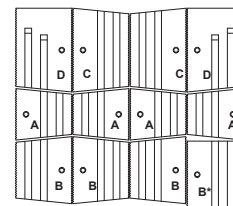

## NOTES

### COMPATIBLE CAPS

See page 6 for icons description.

See page 145 for product compatibility.

When building a double-sided wall one pallet will cover an average of 21.76 ft<sup>2</sup>.

**B\*** unit can be used as a regular or vertical unit.

See page 146 to 161 for more technical information.

D 

P **PATENT**  
CND 2,114,677  
US 5,528,873

# MINI-CRETA 6" Architectural

**DESCRIPTION:** Wall double-sided **TEXTURE:** Split face with straight edged corners

## Pallet Overview

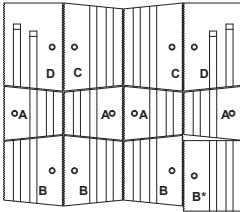

Split face  
straight edged  
corners  
**Chestnut Brown**

Split face  
straight edged  
corners  
**Café Crema**

Split face  
straight edged  
corners  
**Sandlewood**

Split face  
straight edged  
corners  
**Champlain Grey**

Split face  
straight edged  
corners  
**Greyed Nickel**

Split face  
straight edged  
corners  
**Shale Grey**

## Specifications per pallet



20 units / pallet



15 units / pallet



5 units / pallet

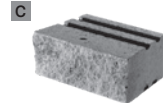

10 units / pallet

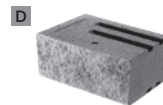

10 units / pallet

5 right corners  
5 left corners

	Imperial	Metric
Dimension Front (L x D x H) <b>A</b>	9 1/16 x 9 13/16 x 5 7/8	230 x 250 x 150
Dimension Back (L x D x H) <b>A</b>	7 1/16 x 9 13/16 x 5 7/8	180 x 250 x 150
Dimension Front (L x D x H) <b>B</b>	11 13/16 x 9 13/16 x 5 7/8	300 x 250 x 150
Dimension Back (L x D x H) <b>B</b>	9 13/16 x 9 13/16 x 5 7/8	250 x 250 x 150
Dimension Front (L x D x H) <b>B*</b>	11 13/16 x 9 13/16 x 5 7/8	300 x 250 x 150
Dimension Back (L x D x H) <b>B*</b>	11 13/16 x 9 13/16 x 5 7/8	300 x 250 x 150
Dimension Front (L x D x H) <b>C</b>	14 3/4 x 9 13/16 x 5 7/8	375 x 250 x 150
Dimension Back (L x D x H) <b>C</b>	12 13/16 x 9 13/16 x 5 7/8	325 x 250 x 150
Dimension Front (L x D x H) <b>D</b>	14 3/4 x 9 13/16 x 5 7/8	375 x 250 x 150
Dimension Back (L x D x H) <b>D</b>	13 3/4 x 9 13/16 x 5 7/8	350 x 250 x 150
Cubing	30 ft <sup>2</sup>	2.79 m <sup>2</sup>
Approx. Weight	59.38 lbs	1 400 kg
Minimum radius	7 ft	2.1 m
Number of rows	5	
Coverage per row	6 ft <sup>2</sup>	0.56 m <sup>2</sup>
Lin. coverage per row	11.88 lin. ft	3.62 lin. m

## NOTES

See page 6 for icons description.

### COMPATIBLE CAPS

See page 145 for product compatibility.

When building a double-sided wall one pallet will cover an average of 27.21 ft<sup>2</sup>.

**B\*** unit can be used as a regular or vertical unit.

See page 146 to 161 for more technical information.



## PILLAR 24" Mini-Creta Architectural

**DESCRIPTION:** Pillar **TEXTURE:** Split face with straight edged corners

### PILLAR 24" × 6"

#### Specifications per pallet

	Imperial	Metric
Product dimension (L × D × H)	16 × 8 × 5 7/8	406 × 203 × 150
Cubing	24 units	24 units
Approx. Weight	1 510 lbs	685 kg
Number of rows	3	
Pillar height	35 7/8 in	900 mm

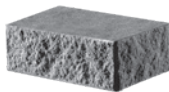

24 units / pallet

### Pallet Overview

			A

**Chestnut Brown**  
Split face  
straight edged  
corners



**Carifè Crema**  
Split face  
straight edged  
corners

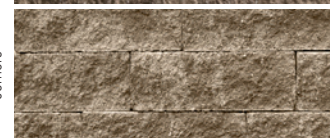

**Sandlewood**  
Split face  
straight edged  
corners

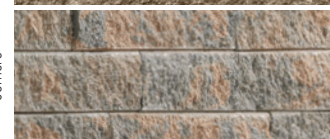

**Champlain Grey**  
Split face  
straight edged  
corners

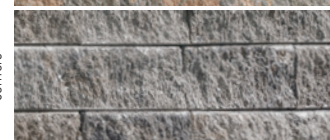

**Greyed Nickel**  
Split face  
straight edged  
corners



**Shale Grey**  
Split face  
straight edged  
corners



### NOTES

See page 6 for icons description.

#### COMPATIBLE CAPS

See page 145 for product compatibility.

See page 146 to 161 for more technical information.

# TECHO—BLOC

## DESIGN CHART MINI-CRETA 6"

(EQUIVALENT TO TWICE THE MINI-CRETA 3")  
SETBACK POSITION

CLEAN SAND/GRAVEL/ SAND AND GRAVEL MIXES ( $\phi=34^\circ$ ,  $\gamma = 120$  pcf)  
GEOGRID: MIRAGRID 3XT BY TENCATE (RFd=1.10, RFcr=1.45, RFid=1.25, Cds=0.9, Ci=0.9)

**CASE N° 1 :**  
No Surcharge  
No Backslope  
No Toe Slope

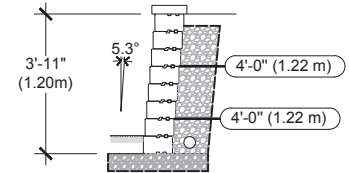
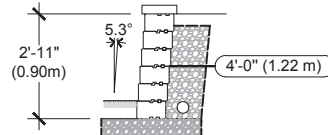
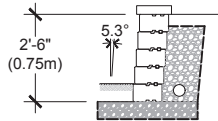

VISIT [WWW.TECHO-BLOC.COM](http://WWW.TECHO-BLOC.COM) FOR COMPLETE DESIGN CHART DOCUMENT  
(USA AND CANADA VERSIONS)

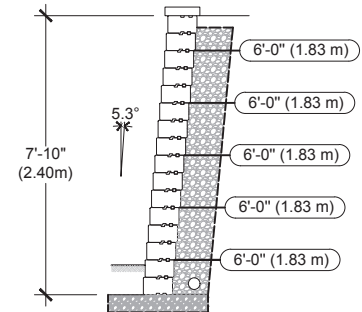
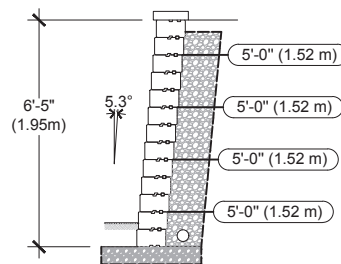
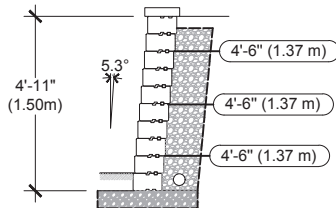

1. The information contained in the design charts is supplied for information purposes only and as such should only be used for preliminary designs.
2. The height (H) of the wall is the total height from the leveling pad to the top of the wall not including the thickness of the cap.
3. Soil parameters: reinforced soil ( $\phi = 34^\circ$ ,  $\gamma = 120$  pcf); retained soil ( $\phi = 34^\circ$ ,  $\gamma = 120$  pcf); foundation soil ( $\phi = 34^\circ$ ,  $\gamma = 120$  pcf)
4. A qualified engineer should be consulted for the final design to be used for construction.
5. The foundation soil must be able to support the wall system. The bearing capacity of the foundation soil, settlement, and global stability must be verified and validated by a qualified geotechnical engineer.
6. The seismic analysis is not included.
7. The design charts do not apply to tiered walls.
8. The charts assume that the walls are constructed in accordance with Techo-Bloc specifications, good construction practice and an adequate drainage system.
9. The geogrid layout has been optimized to satisfy the design requirements of the NCMA's Design Manual for Segmental Retaining Walls, 3rd Edition.
10. The minimum burial depth must be 6 in (150 mm) or 10% of the exposed height, whichever is greater.
11. Engineering judgement should be used when interpolating between heights.
12. Techo-Bloc and its predecessors, successors, beneficiaries, employees, associates, administrators and insurers accepts no liability for the incorrect use of information contained in the design charts.
13. For further information, please contact our technical service department.

# INSTALLATION GUIDE

## RETAINING WALLS - MINI-CRETA 3" AND 6"

The different modules of the Mini-Creta retaining wall allow the installation of different block combinations.

Twelve combinations are shown as an example. Combinations are 20 7/8" (530 mm) or 23 7/8" (605 mm) long and 8 7/8" (225 mm) high.

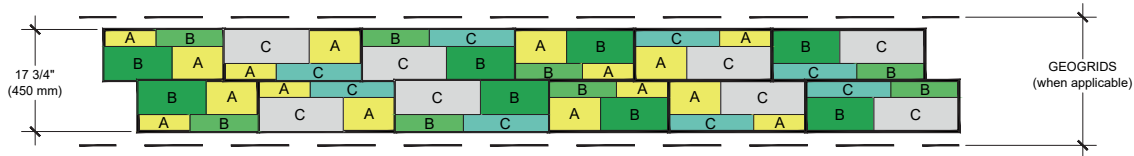
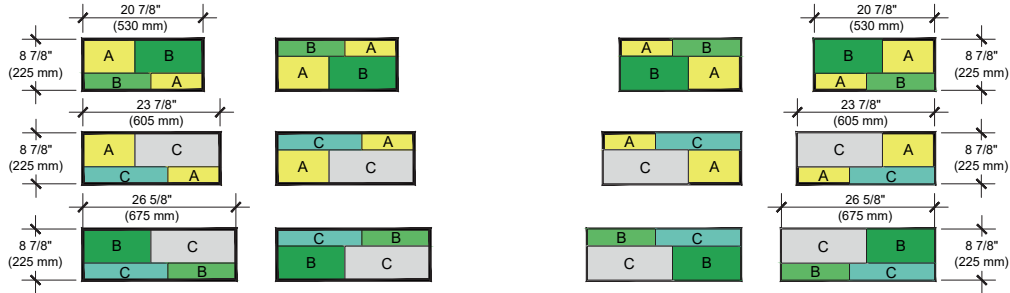

NUMBER OF BLOCKS REQUIRED

MODULE

MINI-CRETA

A

B OR B\*

C OR D

33% of the surface - Mini-Creta 3"

8

8

8

67% of the surface - Mini-Creta 6"

8

8

8

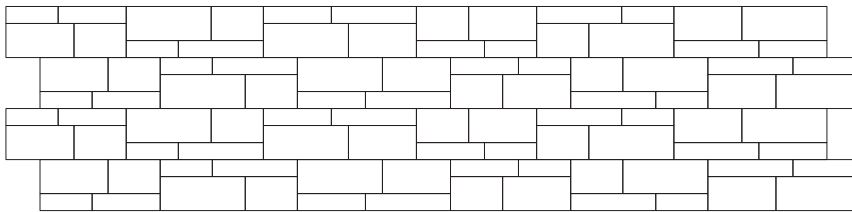

# INSTALLATION GUIDE

## FREESTANDING WALLS - MINI-CRETA 3" AND 6"

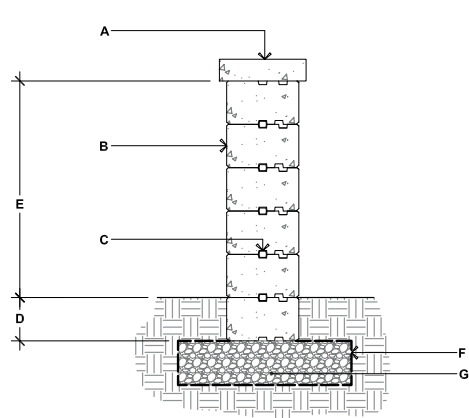

### MINI-CRETA 3" & 6"

- A. TECO-BLOC CAP UNIT SECURED TO UNIT BELOW WITH CONCRETE ADHESIVE
- B. MINI-CRETA 3" AND 6" DOUBLE-SIDED WALL UNITS SECURE EACH ROW WITH CONCRETE ADHESIVE
- C. CONNECTOR
- D. EMBEDMENT DEPTH, 6" (150 mm) MIN.
- E. 29 7/16" (750 mm) MAX.
- F. GEOTEXTILE
- G. COMPACTED GRANULAR LEVELING PAD, 6" (150 mm) THICK MIN. THICKNESS ACCORDING TO PROJECT SPECIFIC CONDITIONS

## 90° CORNER OF A DOUBLE-SIDED WALL

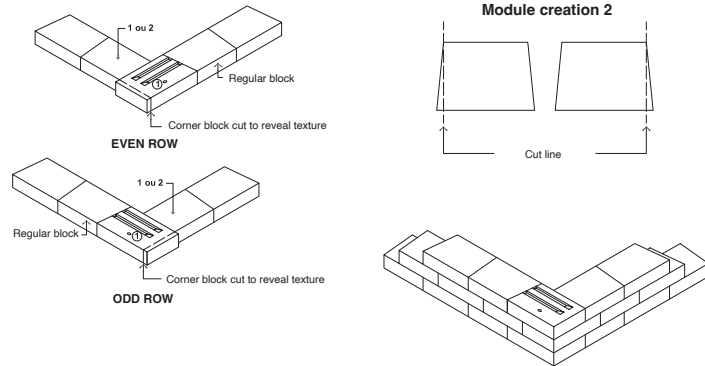

### The corner block must be cut to reveal the texture

1. Alternate odd and even rows.
2. Stagger joints from one row to the next.
3. Glue all modules at each row with concrete adhesive.
4. Cavities, grooves and connectors are not illustrated to avoid overloading the image.
5. It is possible to alternate the blocks (A, B or C) in the same row to create different patterns. However, a corner block must always be present at the end of a row and must be alternated for each subsequent row.

## DOUBLE-SIDED WALL - END OF A STRAIGHT WALL

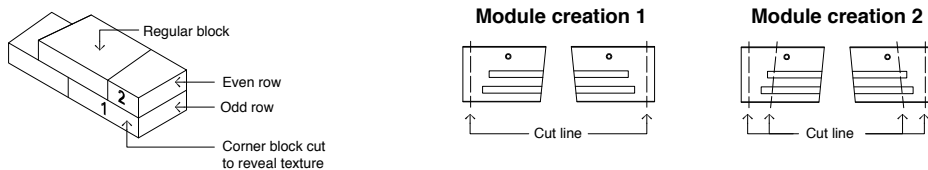

\* It is possible to alternate the blocks (A, B or C) in the same row to create different patterns. However, a corner block must always be present at the end of a row and must be alternated for each subsequent row.

# INSTALLATION GUIDE

## DOUBLE-SIDED WALL RADIUS - MINI-CRETA 3" AND 6"

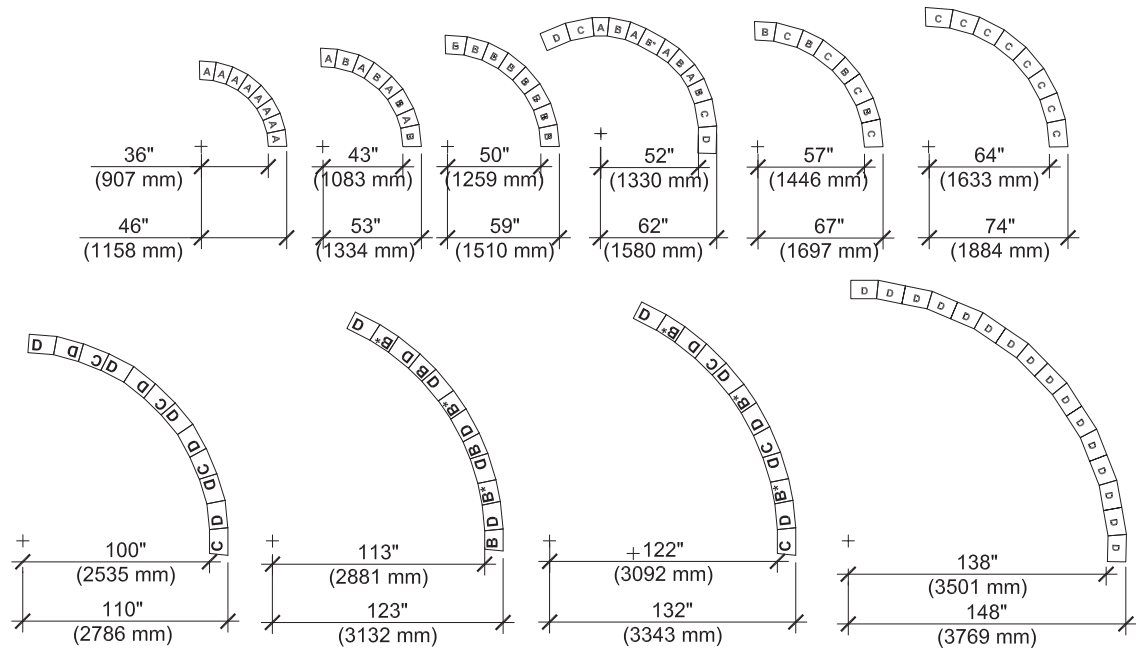

IT IS THE USER'S RESPONSIBILITY TO VERIFY FOR THE QUANTITY OF MATERIALS REQUIRED.

It is the user's responsibility to verify for the quantity of materials required.

## STEPS

### MINI-CRETA 3"

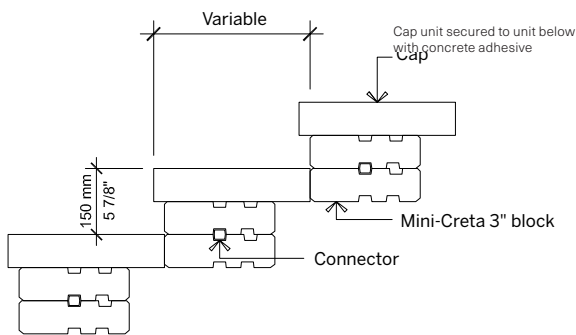

### MINI-CRETA 6"

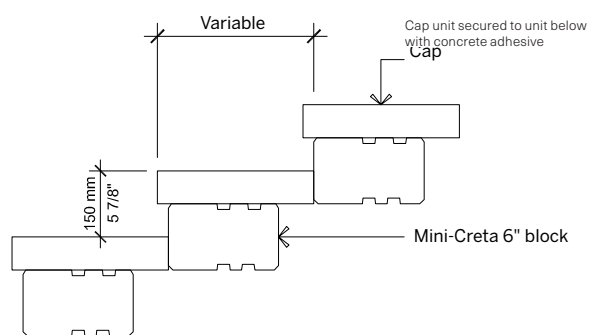

For all possible combinations of pillars and caps, please refer to the correspondence table on page 145

Check with your local Building Codes to determine any restrictions or guidelines regarding the dimensions of steps (including riser height and step tread) as well as handrail specifications.

# INSTALLATION GUIDE

## PILLARS- MINI-CRETA 3" AND 6"

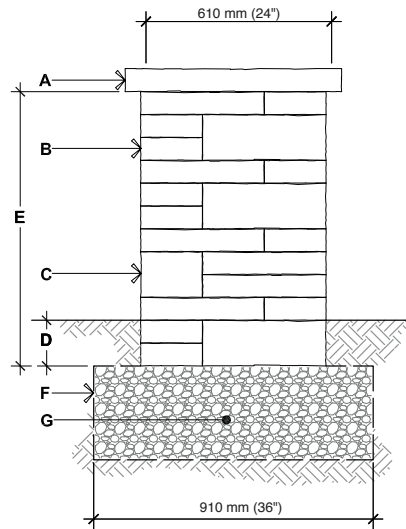
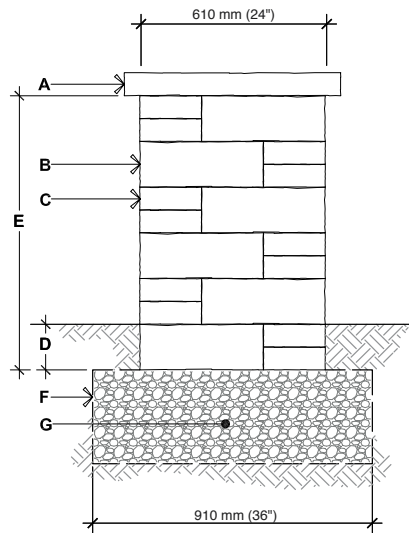

### PILLAR 24"×3" & 24"×6" MINI-CRETA - OPTION A

- A. PILLAR CAP UNIT  
(SECURE WITH CONCRETE ADHESIVE)
- B. PILLAR 24" × 6" (MINI-CRETA) UNIT  
SECURE EACH ROW WITH CONCRETE  
ADHESIVE
- C. PILLAR 24" × 3" (MINI-CRETA) UNIT SECURE  
EACH ROW WITH CONCRETE ADHESIVE
- D. EMBEDMENT 6" (150 mm) MIN.
- E. 35 7/16" (900 mm)  
47 1/4" (1200 mm), MAXIMUM HEIGHT
- F. GEOTEXTILE
- G. COMPACTED GRANULAR BASE 150 mm (6")  
THICK MIN. THICKNESS ACCORDING TO  
PROJECT SPECIFIC CONDITIONS

### PILLAR 24"×3" & 24"×6" MINI-CRETA - OPTION B

- A. PILLAR CAP UNIT  
(SECURE WITH CONCRETE ADHESIVE)
- B. PILLAR 24" × 3" (MINI-CRETA) UNIT  
SECURE EACH ROW WITH CONCRETE  
ADHESIVE
- C. PILLAR 24" × 6" (MINI-CRETA) UNIT  
SECURE EACH ROW WITH CONCRETE  
ADHESIVE
- D. EMBEDMENT 6" (150 mm) MIN.
- E. 35 7/16" (900 mm)  
47 1/4" (1200 mm), MAXIMUM HEIGHT
- F. GEOTEXTILE
- G. COMPACTED GRANULAR BASE 150 mm (6")  
THICK MIN. THICKNESS ACCORDING TO  
PROJECT SPECIFIC CONDITIONS

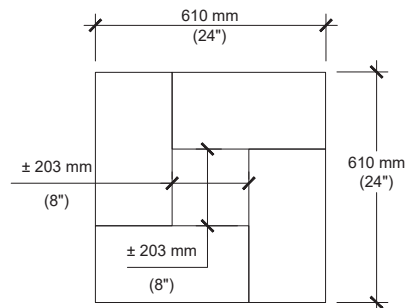

For all possible combinations of pillars and caps, please refer to the correspondence table on page 145

# INSTALLATION GUIDE

## PILLARS- MINI-CRETA 3" AND 6"

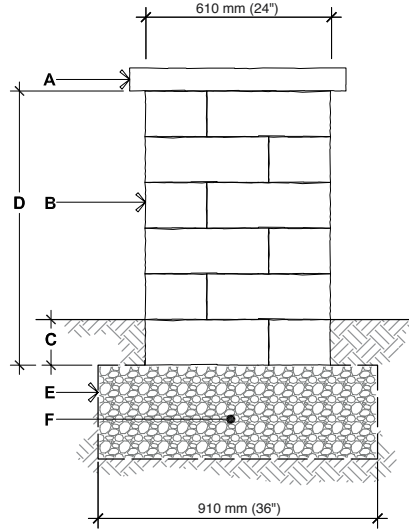
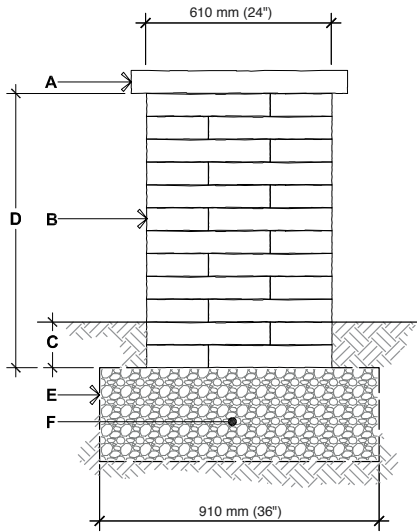

### PILLAR 24"x3"

#### MINI-CRETA

- A. PILLAR CAP UNIT  
(SECURE WITH CONCRETE ADHESIVE)
- B. PILLAR 24" x 3" (MINI-CRETA) UNIT  
SECURE EACH ROW WITH CONCRETE  
ADHESIVE
- C. EMBEDMENT 6" (150 mm) MIN.
- D. 35 7/16" (900 mm), HEIGHT PER PALLET  
47 1/4" (1200 mm), MAXIMUM HEIGHT
- E. GEOTEXTILE
- F. COMPACTED GRANULAR BASE 150 mm  
(6") THICK MIN. THICKNESS ACCORDING  
TO PROJECT SPECIFIC CONDITIONS

### PILLAR 24"x6"

#### MINI-CRETA

- A. PILLAR CAP UNIT  
(SECURE WITH CONCRETE ADHESIVE)
- B. PILLAR 24" x 6" (MINI-CRETA) UNIT  
SECURE EACH ROW WITH CONCRETE  
ADHESIVE
- C. EMBEDMENT 6" (150 mm) MIN.
- D. 35 7/16" (900 mm), HEIGHT PER PALLET  
47 1/4" (1200 mm), MAXIMUM HEIGHT
- E. GEOTEXTILE
- F. COMPACTED GRANULAR BASE 150 mm (6")  
THICK MIN. THICKNESS ACCORDING TO  
PROJECT SPECIFIC CONDITIONS

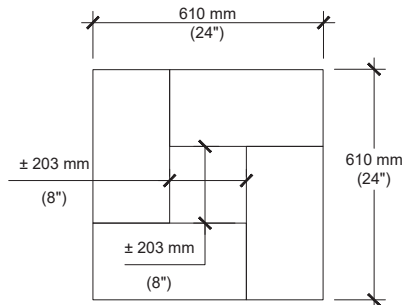

For all possible combinations of pillars and caps, please refer to the correspondence table on page 145

# INSTALLATION GUIDE

## GRILL ISLAND 6 FT - MINI-CRETA 3" AND 6"

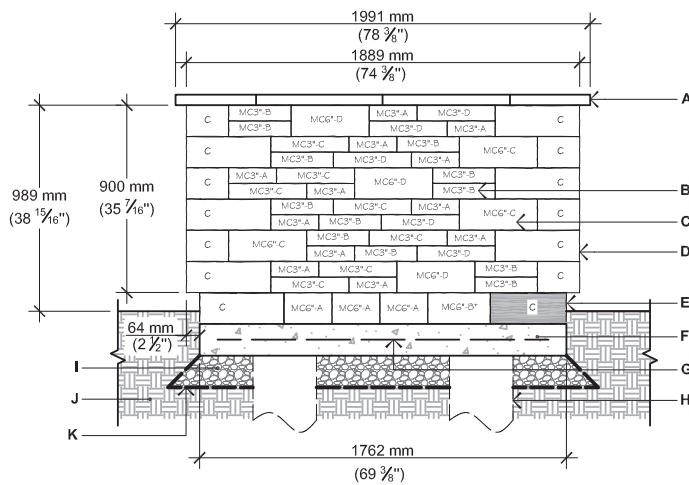
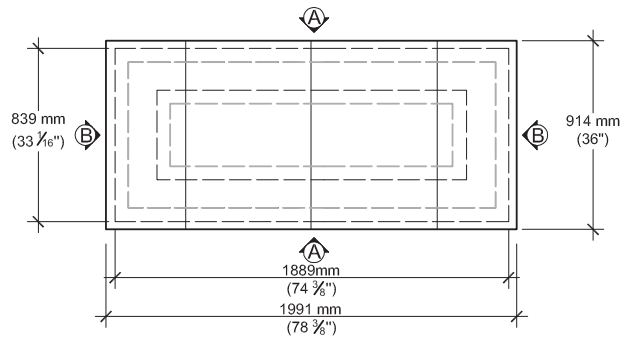

ELEVATION A

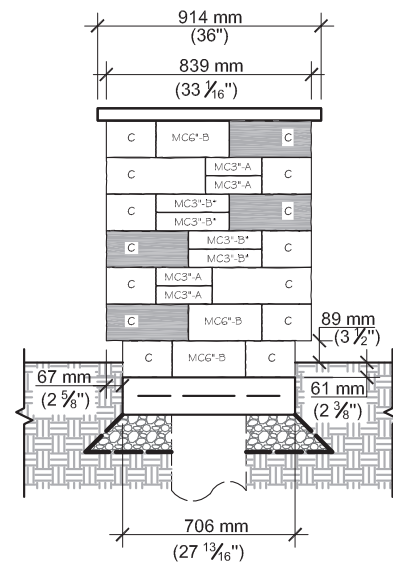

ELEVATION B

- A. YORK COUNTER TOP 24" × 36" × 2 1/4"
- B. MINI-CRETA 3" UNIT (A, B, B\*, C, OR D)
- C. MINI-CRETA 6" UNIT (A, B, B\*, C, OR D)
- D. PILLAR 24" × 36" (MINI-CRETA) UNIT
- E. PILLAR 24" × 36" (MINI-CRETA) UNIT (CUT ON FIELD)
- F. CAST IN PLACE CONCRETE SLAB 4350 psi (30 MPa), 5" (125 mm) THICK
- G. 4X4-4/4 (102X102-MW25.8XMW25.8) WELDED WIRE MESH AND/OR REBAR AS PER SITE CONDITIONS
- H. 12" (300 mm) DIA. CONCRETE PILLAR, AS PER LOCAL CODE
- I. 3/4" (20 mm) CLEAN STONE 6" (150 mm) THICK MIN. AS PER SITE CONDITIONS
- J. NATURAL SOIL OR COMPACTED BACKFILL
- K. GEOTEXTILE

### QUANTITY OF MATERIALS REQUIRED

- York Counter top 24" × 36" × 2 1/4": **4**
- Mini-Creta 3" unit: **32 A, 24 B, 8 B\*, 14 C, 10 D**
- Mini-Creta 6" unit: **6 A, 6 B, 2 B\*, 6 C, 6 D**
- Pillar 24" × 6" (Mini-Creta) unit: **28**

**NOTE:** Appliances and utilities may vary for each project and are not shown on this drawing. This drawing is shown for inspiration only and surplus or shortage of materials may result. It is the user's responsibility to verify for the quantity of materials required. Secure the blocks using a heat resistant concrete adhesive. The installer must ensure that the installation and use of the grill island comply with local regulations and code requirements. Concrete pillars extending to frost line may be required as per local code. Check your local building code before installing.

# INSTALLATION GUIDE

## SQUARE FIRE PIT - MINI-CRETA 3" AND 6"

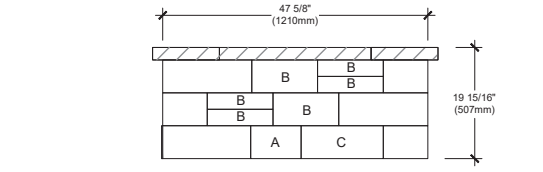
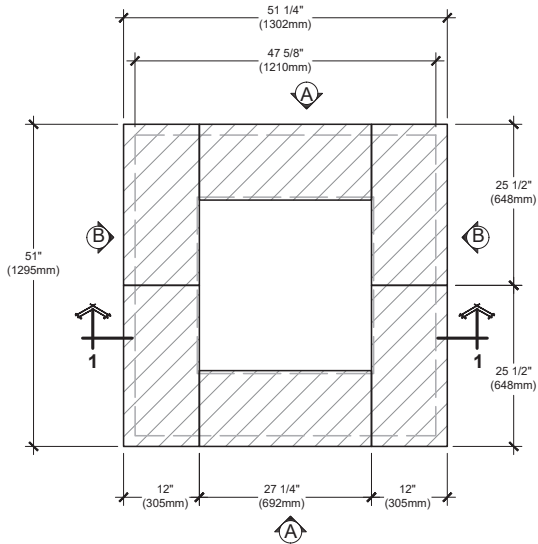

ELEVATION A

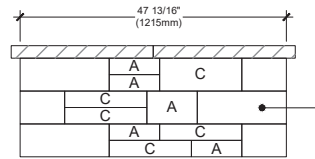

ELEVATION B

TOP

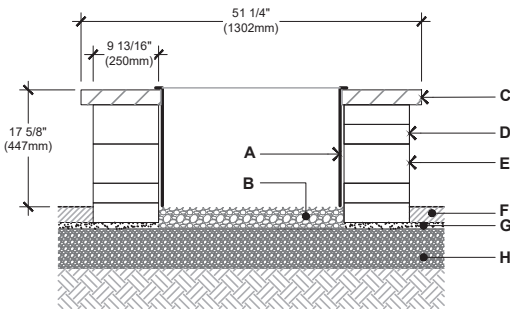

CUT ON FIELD

SECTION 1-1

- A. STEEL BOX INSERT
- B. CLEAN CTONE 3/4" (20 mm), 4" (100 mm) THICK
- C. PIEDIMONTE CAP (12"X30")
- D. MINI-CRETA 3" BLOCK
- E. MINI-CRETA 6" BLOCK
- F. TECO-BLOC PAVERS OR SLABS
- G. SETTING BED 1" (25 mm)
- H. COMPACTED GRANULAR 0-3/4" (0-20 mm)
- I. PILLAR 24"X6" MINI-CRETA

### QUANTITY OF MATERIALS REQUIRED

- Piedimonte Cap: 6
- Mini-Creta 3" **A**: 8
- Mini-Creta 3" (**B** or **B\***): 8
- Mini-Creta 3" (**C** or **D**): 8
- Mini-Creta 6" **A**: 4
- Mini-Creta 6" (**B** or **B\***): 4
- Mini-Creta 6" (**C** or **D**): 4
- Pillar 24"x6" Mini-Creta: 12

**NOTE :** Secure the blocks using a heat resistant concrete adhesive. The installer must ensure that the installation and use of the firepit comply with local regulations and code requirements.



# PRESCOTT 2.25"

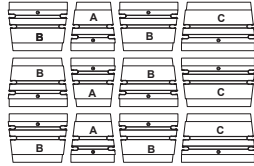

**DESCRIPTION:** Wall double-sided **TEXTURE:** Chiseled Face

## Pallet Overview



Chiseled Face  
Rock Garden Brown  
Victoria  
Riviera

## Specifications per pallet

		Imperial	Metric
<b>A</b> 	Dimension Front (L x D x H) <b>A</b>	9 x 9 13/16 x 2 1/4	229 x 250 x 57
	Dimension Back (L x D x H) <b>A</b>	7 7/16 x 9 13/16 x 2 1/4	189 x 250 x 57
36 units / pallet	Dimension Front (L x D x H) <b>B</b>	12 x 9 13/16 x 2 1/4	305 x 250 x 57
	Dimension Back (L x D x H) <b>B</b>	10 7/16 x 9 13/16 x 2 1/4	265 x 250 x 57
<b>B</b> 	Dimension Front (L x D x H) <b>C</b>	15 x 9 13/16 x 2 1/4	381 x 250 x 57
	Dimension Back (L x D x H) <b>C</b>	13 7/16 x 9 13/16 x 2 1/4	341 x 250 x 57
72 units / pallet	Cubing	27 ft <sup>2</sup>	2.51 m <sup>2</sup>
		144 lin. ft	43.89 lin. m
<b>C</b> 	Approx. Weight	2 661 lbs	1 207 kg
	Minimum radius	5.2 ft	1.6 m
36 units / pallet	Number of rows	12	
	Coverage per row	2.25 ft <sup>2</sup>	0.21 m <sup>2</sup>
	Lin. coverage per row	12 lin. ft	3.66 lin. m

## NOTES

See page 6 for icons description.

### COMPATIBLE CAPS

See page 145 for product compatibility.

When building a double-sided wall one pallet will cover an average of 25.23 ft<sup>2</sup>.

\*For an authentic look, each color option is composed of a variety of darker & lighter tones. Natural ingredients such as granite are present within the recipe to allow for a range in tones, veining and textures from one stone to another.



The dimensional tolerance for Stonedge wet cast retaining wall units is: ± 3/16" (5 mm) for height and ± 1/2" (13 mm) for length and width. During the installation, the level between adjacent wall units will vary (usually more than for a dry cast wall unit) in order to obtain a more realistic appearance of a natural stone wall.

See page 146 to 161 for more technical information.



# PRESCOTT 4.5"

DESCRIPTION: Wall double-sided TEXTURE: Chiseled Face

Specifications per pallet	Imperial	Metric	
<b>A</b>  18 units / pallet	Dimension Front (L x D x H) <b>A</b>	9 x 9 13/16 x 4 1/2	229 x 250 x 114
	Dimension Back (L x D x H) <b>A</b>	7 7/16 x 9 13/16 x 4 1/2	189 x 250 x 114
<b>B</b>  36 units / pallet	Dimension Front (L x D x H) <b>B</b>	12 x 9 13/16 x 4 1/2	305 x 250 x 114
	Dimension Back (L x D x H) <b>B</b>	10 7/16 x 9 13/16 x 4 1/2	265 x 250 x 114
<b>C</b>  18 units / pallet	Dimension Front (L x D x H) <b>C</b>	15 x 9 13/16 x 4 1/2	381 x 250 x 114
	Dimension Back (L x D x H) <b>C</b>	13 7/16 x 9 13/16 x 4 1/2	341 x 250 x 114
Cubing	27 ft <sup>2</sup>	2.51 m <sup>2</sup>	
	72 lin. ft	21.95 lin. m	
Approx. Weight	2 728 lbs	1 237 kg	
Minimum radius	5.2 ft	1.6 m	
Number of rows	6		
Coverage per row	4.50 ft <sup>2</sup>	0.42 m <sup>2</sup>	
Lin. coverage per row	12 lin. ft	3.66 lin. m	

## Pallet Overview

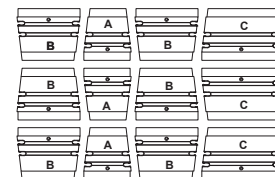

Rock Garden Brown

Chiseled Face

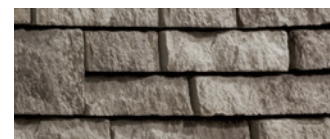

Victoria

Chiseled Face



Riviera

Chiseled Face

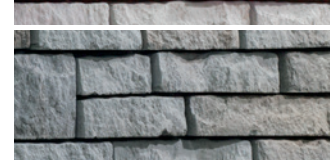

## NOTES

See page 6 for icons description.

### COMPATIBLE CAPS

See page 145 for product compatibility.

When building a double-sided wall one pallet will cover an average of 25.23 ft<sup>2</sup>.

\*For an authentic look, each color option is composed of a variety of darker & lighter tones. Natural ingredients such as granite are present within the recipe to allow for a range in tones, veining and textures from one stone to another.

The dimensional tolerance for Stonedge wet cast retaining wall units is: ± 3/16" (5 mm) for height and ± 1/2" (13 mm) for length and width. During the installation, the level between adjacent wall units will vary (usually more than for a dry cast wall unit) in order to obtain a more realistic appearance of a natural stone wall.

See page 146 to 161 for more technical information.



# PRESCOTT

**DESCRIPTION:** Corners and pillars **TEXTURE:** Chiseled Face

## Pallet Overview

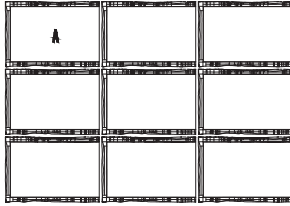

Chiseled Face  
Rock Garden Brown  
Chiseled Face  
Victoria  
Chiseled Face  
Riviera

### 2.25"

#### Specifications per pallet

	Imperial	Metric
Product dimension (L x D x H)	14 3/16 x 9 13/16 x 2 1/4	360 x 250 x 57
 Cubing	72 units	72 units
Approx. Weight	1 789 lbs	811 kg
72 units / pallet	Number of rows	8
Pillar height	40 1/2 in	1 029 mm

### 4.5"

#### Specifications per pallet

	Imperial	Metric
Product dimension (L x D x H)	14 3/16 x 9 13/16 x 4 1/2	360 x 250 x 114
 Cubing	36 units	36 units
Approx. Weight	1 871 lbs	849 kg
36 units / pallet	Number of rows	4
Pillar height	40 1/2 in	1 029 mm

## NOTES

See page 6 for icons description.

### COMPATIBLE CAPS

See page 145 for product compatibility.

\*For an authentic look, each color option is composed of a variety of darker & lighter tones. Natural ingredients such as granite are present within the recipe to allow for a range in tones, veining and textures from one stone to another.

The dimensional tolerance for Stonedge wet cast retaining wall units is: ± 3/16" (5 mm) for height and ± 1/2" (13 mm) for length and width. During the installation, the level between adjacent wall units will vary (usually more than for a dry cast wall unit) in order to obtain a more realistic appearance of a natural stone wall.

See page 146 to 161 for more technical information.

## RETAINING WALLS - PRESCOTT

The different modules of the Prescott retaining wall allow the installation of different block combinations.

Eight combinations are shown as an example. Each combination is 24" (610 mm) long and 6 3/4" (171 mm) high.

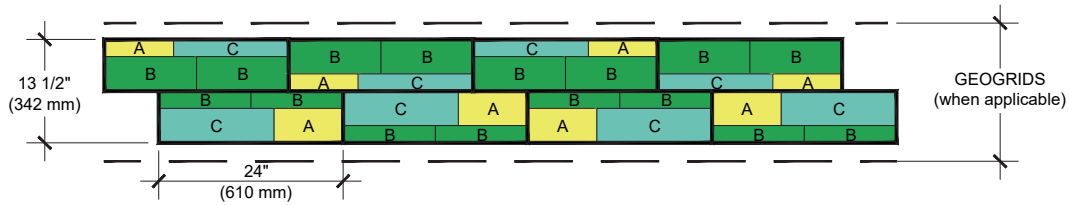
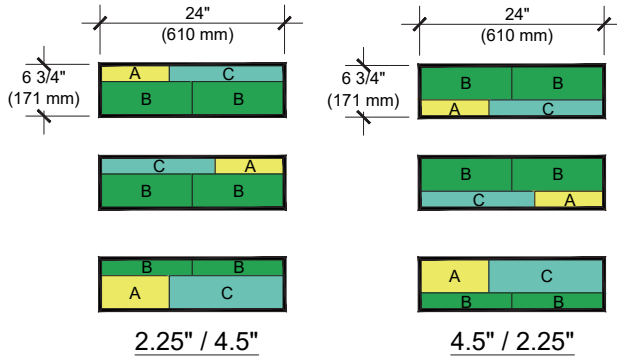

NUMBER OF BLOCKS REQUIRED

MODULE

PRESCOTT

	A	B	C
33% of the surface - Prescott 2.25"	4	8	8
67% of the surface - Prescott 4.5"	2	8	2

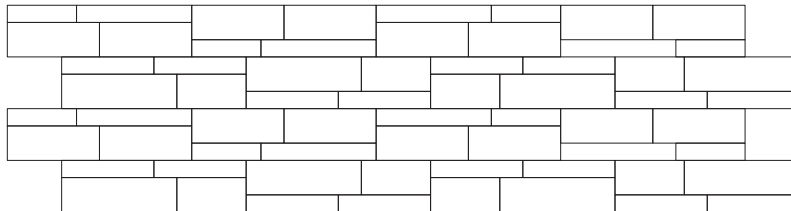

# INSTALLATION GUIDE

## FREESTANDING WALLS - PRESCOTT 2.25" & 4.5"

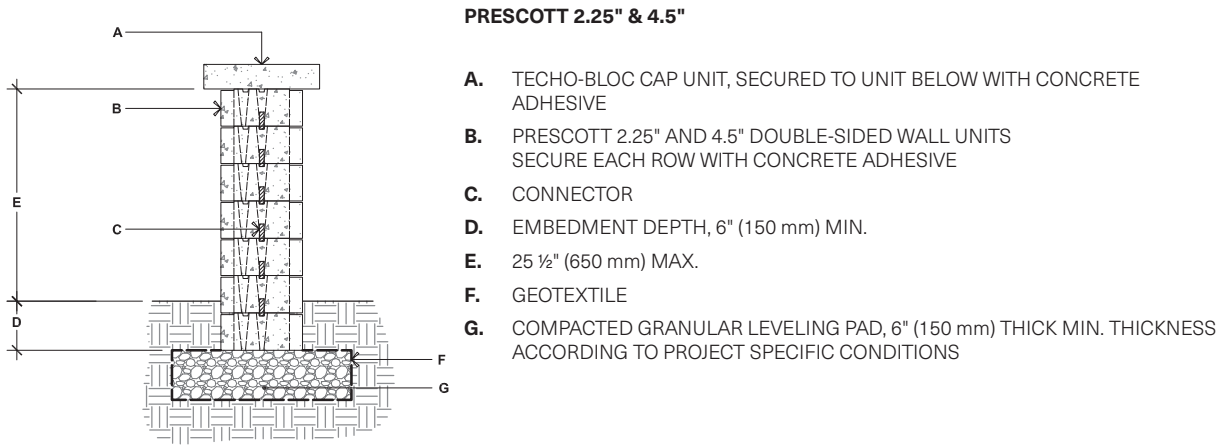

## 90° CORNER OF A DOUBLE-SIDED WALL

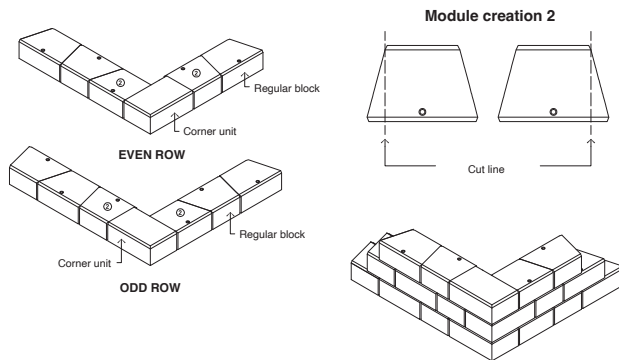

## DOUBLE-SIDED WALL - END OF A STRAIGHT WALL

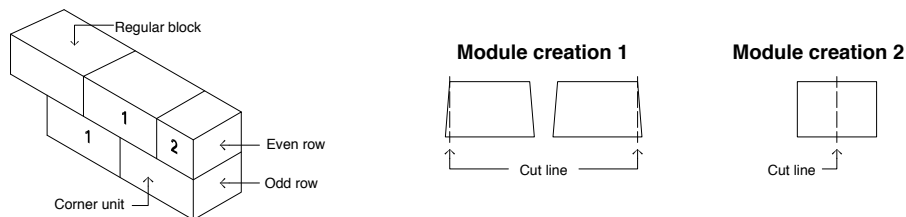

### GENERAL NOTES

1. Alternate odd and even rows.
2. Stagger joints from one row to the next.
3. Glue all modules at each row with concrete adhesive.
4. Cavities, grooves and connectors are not illustrated to avoid overloading the image.

# INSTALLATION GUIDE

## DOUBLE-SIDED WALL RADIUS - PRESCOTT 2.25" & 4.5"

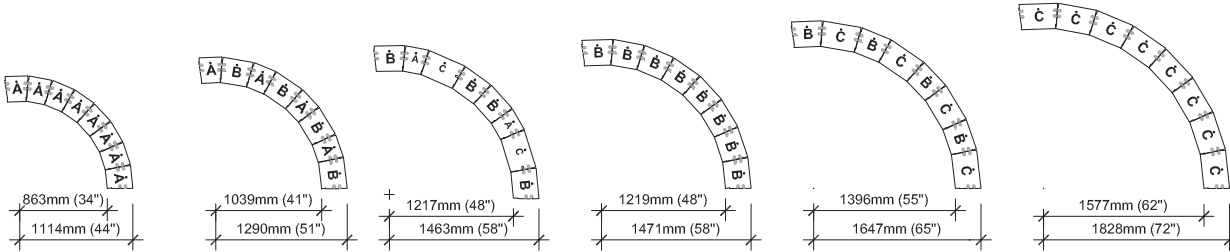

It is the user's responsibility to verify for the quantity of materials required.

## STEPS

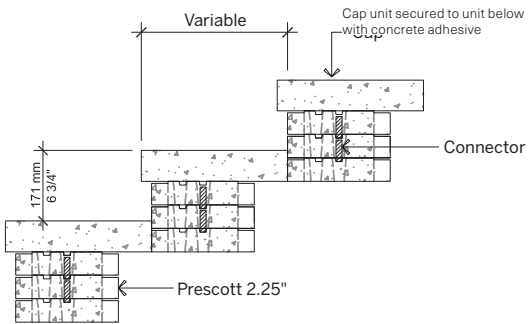

For all possible combinations of pillars and caps, please refer to the correspondence table on page 145

Check with your local Building Codes to determine any restrictions or guidelines regarding the dimensions of steps (including riser height and step tread) as well as handrail specifications.

# INSTALLATION GUIDE

## PILLARS - PRESCOTT 2.25" & 4.5"

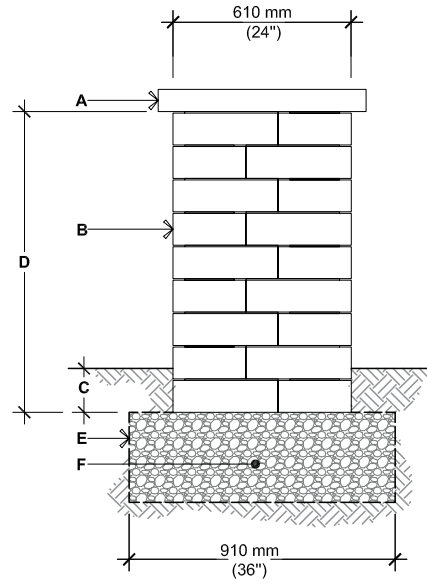
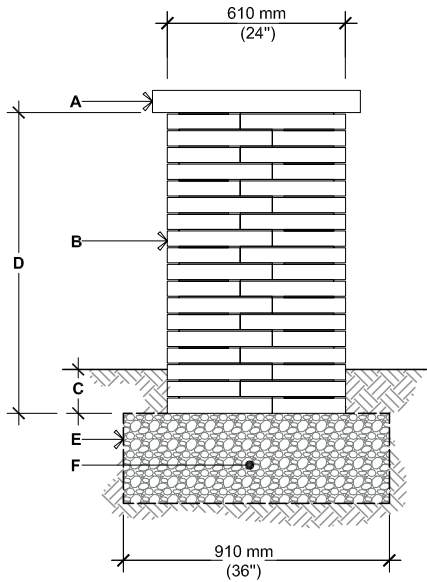

### PRESCOTT 2.25"

- A. PILLAR CAP UNIT  
(SECURE WITH CONCRETE ADHESIVE)
- B. PRESCOTT 2.25" PILLAR UNIT SECURE EACH ROW WITH CONCRETE ADHESIVE
- C. EMBEDMENT DEPTH, 6" (150 mm) MIN.
- D. 40 1/2" (1 029 mm), HEIGHT PER PALLET  
45" (1 143 mm), MAX. HEIGHT
- E. GEOTEXTILE
- F. COMPACTED GRANULAR BASE 6" (150 mm)  
THICK MIN. THICKNESS ACCORDING TO  
PROJECT SPECIFIC CONDITIONS

### PRESCOTT 4.5"

- A. PILLAR CAP UNIT  
(SECURE WITH CONCRETE ADHESIVE)
- B. PRESCOTT 4.5" PILLAR UNIT SECURE EACH ROW  
WITH CONCRETE ADHESIVE
- C. EMBEDMENT DEPTH, 6" (150 mm) MIN.
- D. 40 1/2" (1 029 mm), HEIGHT PER PALLET  
45" (1 143 mm), MAX. HEIGHT
- E. GEOTEXTILE
- F. COMPACTED GRANULAR BASE  
6" (150 mm) THICK MIN. THICKNESS ACCORDING  
TO PROJECT SPECIFIC CONDITIONS

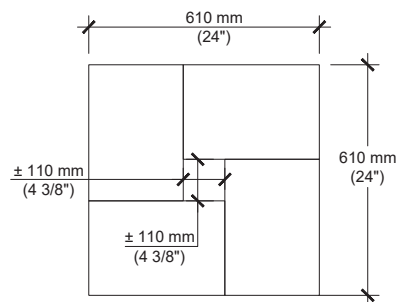

For all possible combinations of pillars and caps, please refer to the correspondence table on page 145

# INSTALLATION GUIDE

## PILLARS - PRESCOTT 2.25" & 4.5"

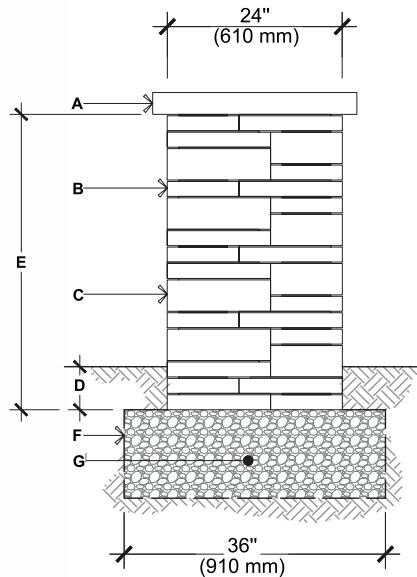
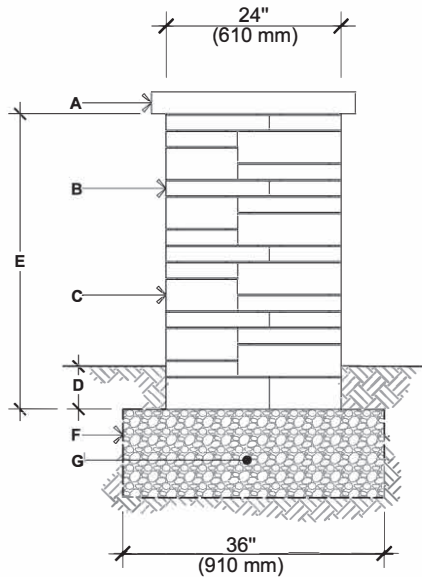

### PRESCOTT 2.25" & 4.5" OPTION A

- A. PILLAR CAP UNIT (SECURE WITH CONCRETE ADHESIVE)
- B. PRESCOTT 2.25" PILLAR UNIT SECURE EACH ROW WITH CONCRETE ADHESIVE
- C. PRESCOTT 4.5" PILLAR UNIT SECURE EACH ROW WITH CONCRETE ADHESIVE
- D. EMBEDMENT DEPTH, 6" (150 mm) MIN.
- E. 40 1/2" (1 029 mm)  
45" (1 143 mm), MAX. HEIGHT
- F. GEOTEXTILE
- G. COMPACTED GRANULAR BASE 6" (150 mm) THICK MIN. THICKNESS ACCORDING TO PROJECT SPECIFIC CONDITIONS

### PRESCOTT 2.25" & 4.5" OPTION B

- A. PILLAR CAP UNIT (SECURE WITH CONCRETE ADHESIVE)
- B. PRESCOTT 2.25" PILLAR UNIT SECURE EACH ROW WITH CONCRETE ADHESIVE
- C. PRESCOTT 4.5" PILLAR UNIT SECURE EACH ROW WITH CONCRETE ADHESIVE
- D. EMBEDMENT DEPTH, 6" (150 mm) MIN.
- E. 40 1/2" (1 029 mm)  
45" (1 143 mm), MAX. HEIGHT
- F. GEOTEXTILE
- G. COMPACTED GRANULAR BASE 6" (150 mm) THICK MIN. THICKNESS ACCORDING TO PROJECT SPECIFIC CONDITIONS

**NOTE:** Two pillars of 40 1/2" total height (one option A and one option B) required one pallet of Prescott 4.5" Pillar unit and one pallet of Prescott 2.25" Pillar unit.

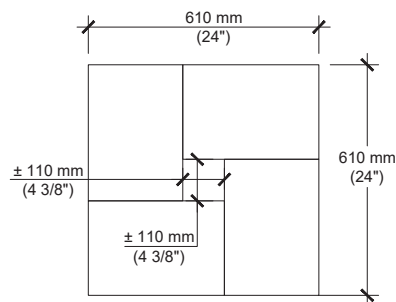

For all possible combinations of pillars and caps, please refer to the correspondence table on page 145

D ❄️

## RAFFINATO 90 & 180 mm

DESCRIPTION: Wall TEXTURE: Polished (on a single-side only)

### Pallet Overview - 90 mm

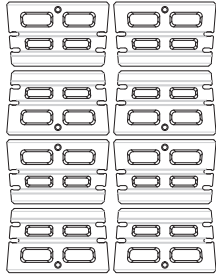

### Pallet Overview - 180 mm

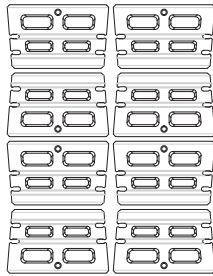

Polished  
Beige Cream

Polished  
Greyed Nickel

Polished  
Onyx Black

### 90 mm

#### Specifications per pallet

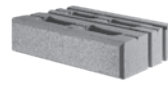

60 units / pallet

	Imperial	Metric
Dimension Front (L x D x H)	15 5/8 x 9 5/8 x 3 3/16	397 x 245 x 90
Dimension Back (L x D x H)	14 1/4 x 9 5/8 x 3 3/16	362 x 245 x 90
Cubing	23.08 ft <sup>2</sup>	2.14 m <sup>2</sup>
Approx. Weight	1 948 lbs	884 kg
Minimum radius	8.5 ft	2.6 m
Number of rows	3	
Coverage per row	7.69 ft <sup>2</sup>	0.71 m <sup>2</sup>
Linear coverage per row	26.05 lin ft	7.94 lin m

### 180 mm

#### Specifications per pallet



30 units / pallet

	Imperial	Metric
Dimension Front (L x D x H)	15 5/8 x 9 5/8 x 7 1/16	397 x 245 x 180
Dimension Back (L x D x H)	14 1/4 x 9 5/8 x 7 1/16	362 x 245 x 180
Cubing	23.08 ft <sup>2</sup>	2.14 m <sup>2</sup>
Approx. Weight	1 936 lbs	878 kg
Minimum radius	8.5 ft	2.6 m
Number of rows	3	
Coverage per row	7.69 ft <sup>2</sup>	0.71 m <sup>2</sup>
Linear coverage per row	13.02 lin ft	3.97 lin m

### NOTES

See page 6 for icons description.

#### COMPATIBLE CAPS

See page 145 for product compatibility.

Polished only on one side, Smooth on the other side.

See page 146 to 161 for more technical information.

**Polished is made-to-order, minimum order of 500 sq. ft. Deposit required.**



## RAFFINATO 90 & 180 mm

DESCRIPTION: Wall double-sided TEXTURE: Smooth

### 90 mm

#### Specifications per pallet



64 units / pallet

	Imperial	Metric
Dimension Front (L x D x H)	15 5/8 x 9 13/16 x 3 9/16	397 x 249 x 90
Dimension Back (L x D x H)	14 1/4 x 9 13/16 x 3 9/16	362 x 249 x 90
Cubing	24.61 ft <sup>2</sup>	2.29 m <sup>2</sup>
Approx. Weight	2 060 lbs	934 kg
Minimum radius	8.5 ft	2.6 m
Number of rows	8	
Coverage per row	3.08 ft <sup>2</sup>	0.29 m <sup>2</sup>
Linear coverage per row	10.42 lin. ft	3.18 lin. m

### 180 mm

#### Specifications per pallet



32 units / pallet

	Imperial	Metric
Dimension Front (L x D x H)	15 5/8 x 9 13/16 x 7 1/16	397 x 249 x 180
Dimension Back (L x D x H)	14 1/4 x 9 13/16 x 7 1/16	362 x 249 x 180
Cubing	24.61 ft <sup>2</sup>	2.29 m <sup>2</sup>
Approx. Weight	2 071 lbs	939 kg
Minimum radius	8.5 ft	2.6 m
Number of rows	4	
Coverage per row	6.15 ft <sup>2</sup>	0.57 m <sup>2</sup>
Linear coverage per row	10.42 lin. ft	3.18 lin. m

### Pallet Overview - 90 mm & 180 mm

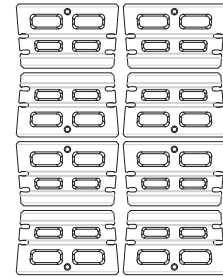

Caffè Crema

Smooth



Beige Cream

Smooth

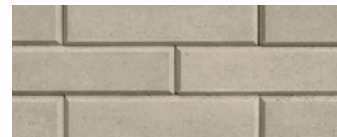

Greyed Nickel

Smooth

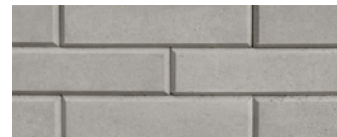

Shale Grey

Smooth



Onyx Black

Smooth

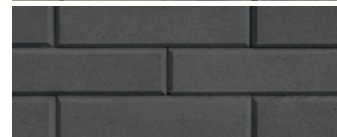

## NOTES

See page 6 for icons description.

### COMPATIBLE CAPS

See page 145 for product compatibility.

When building a double-sided wall one pallet will cover an average of 23.53 ft<sup>2</sup>.

See page 146 to 161 for more technical information.

D ❄️

# RAFFINATO 90 & 180 mm

**DESCRIPTION:** Pillars, corners and edges **TEXTURE:** Polished (on a single-side only)

### Pallet Overview - 90 mm

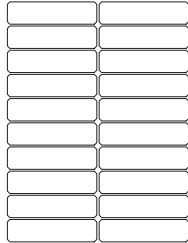

### Pallet Overview - 180 mm

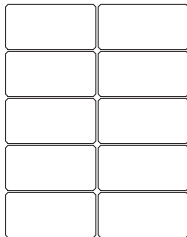

### 90 mm

#### Specifications per pallet

	Imperial	Metric
 Product dimension (L x D x H)	14 1/16 x 9 5/8 x 3 5/16	357 x 245 x 90
Cubing	40 units	40 units
Approx. Weight	1 559 lbs	707 kg
40 units / pallet	Number of rows	2
Pillar height	35 7/16 in	900 mm

### 180 mm

#### Specifications per pallet

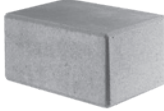
	Imperial	Metric
 Product dimension (L x D x H)	14 1/16 x 9 5/8 x 7 1/16	357 x 245 x 180
Cubing	20 units	20 units
Approx. Weight	1 557 lbs	706 kg
20 units / pallet	Number of rows	2
Pillar height	35 7/16 in	900 mm



Polished  
Beige Cream

Polished  
Greyed Nickel

Polished  
Onyx Black

## NOTES

See page 6 for icons description.

### COMPATIBLE CAPS

See page 145 for product compatibility.

Polished only on one side, Smooth on the other side.

See page 146 to 161 for more technical information.

**Polished is made-to-order, minimum order of 500 sq. ft. Deposit required.**



## RAFFINATO 90 & 180 mm

**DESCRIPTION:** Pillars, corners and edges **TEXTURE:** Smooth

### 90 mm

Specifications per pallet		Imperial	Metric
	Product dimension (L x D x H)	14 1/8 x 9 13/16 x 3 9/16	359 x 249 x 90
	Cubing	48 units	48 units
	Approx. Weight	1 548 lbs	702 kg
	Number of rows	2	
	Pillar height	42 1/2 in	1 080 mm

48 units / pallet

### 180 mm

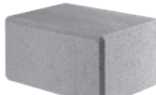
Specifications per pallet		Imperial	Metric
	Product dimension (L x D x H)	14 1/8 x 9 13/16 x 7 1/16	359 x 249 x 180
	Cubing	24 units	24 units
	Approx. Weight	1 529 lbs	694 kg
	Number of rows	2	
	Pillar height	42 1/2 in	1 080 mm

24 units / pallet

### Pallet Overview - 90 mm

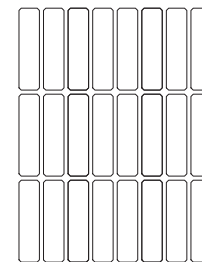

### Pallet Overview - 180 mm

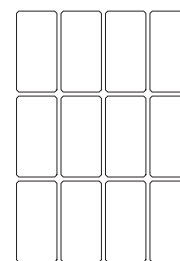

## NOTES

See page 6 for icons description.

### COMPATIBLE CAPS

See page 145 for product compatibility.

See page 146 to 161 for more technical information.

Caffé Crema

Smooth



Beige Cream

Smooth



Greyed Nickel

Smooth

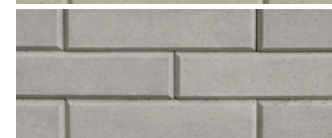

Shale Grey

Smooth



Onyx Black

Smooth



# TECHO—BLOC

## DESIGN CHART RAFFINATO 180 mm

(EQUIVALENT TO TWICE THE RAFFINATO 90 mm)  
SETBACK POSITION

CLEAN SAND/GRAVEL/ SAND AND GRAVEL MIXES ( $\phi=34^\circ$ ,  $\gamma = 120$  pcf)  
GEOGRID: MIRAGRID 3XT BY TENCATE (RFd=1.10, RFcr=1.45, RFid=1.25, Cds=0.9, Ci=0.9)

**CASE N° 1 :**  
No Surcharge  
No Backslope  
No Toe Slope

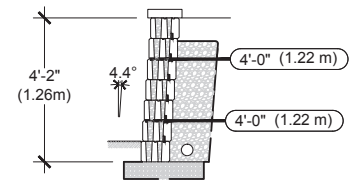
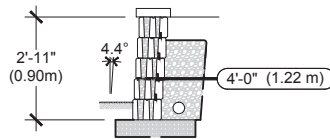
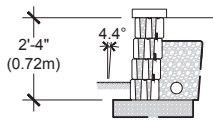

VISIT [WWW.TECHO-BLOC.COM](http://WWW.TECHO-BLOC.COM) FOR COMPLETE DESIGN CHART DOCUMENT  
(USA AND CANADA VERSIONS)

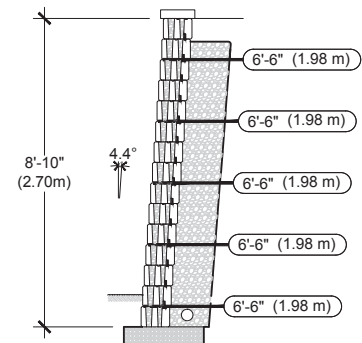
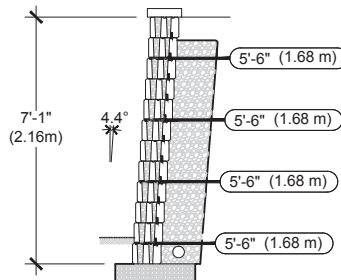
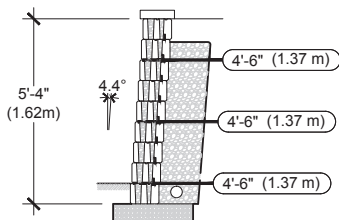

1. The information contained in the design charts is supplied for information purposes only and as such should only be used for preliminary designs.
2. The height (H) of the wall is the total height from the leveling pad to the top of the wall not including the thickness of the cap.
3. Soil parameters: reinforced soil ( $\phi = 34^\circ$ ,  $\gamma = 120$  pcf); retained soil ( $\phi = 34^\circ$ ,  $\gamma = 120$  pcf); foundation soil ( $\phi = 34^\circ$ ,  $\gamma = 120$  pcf)
4. A qualified engineer should be consulted for the final design to be used for construction.
5. The foundation soil must be able to support the wall system. The bearing capacity of the foundation soil, settlement, and global stability must be verified and validated by a qualified geotechnical engineer.
6. The seismic analysis is not included.
7. The design charts do not apply to tiered walls.
8. The charts assume that the walls are constructed in accordance with Tehco-Bloc specifications, good construction practice and an adequate drainage system.
9. The geogrid layout has been optimized to satisfy the design requirements of the NCMA's Design Manual for Segmental Retaining Walls, 3rd Edition.
10. The minimum burial depth must be 6 in (150 mm) or 10% of the exposed height, whichever is greater.
11. Engineering judgement should be used when interpolating between heights.
12. Tehco-Bloc and its predecessors, successors, beneficiaries, employees, associates, administrators and insurers accepts no liability for the incorrect use of information contained in the design charts.
13. For further information, please contact our technical service department.

# INSTALLATION GUIDE

## RETAINING WALLS - RAFFINATO 90 mm & 180 mm

The different modules of the Raffinato retaining wall allow the installation of different block combinations.

Two combinations are shown as an example. Combinations are 15 5/8" (398 mm) long and 10 5/8" (270 mm) high.

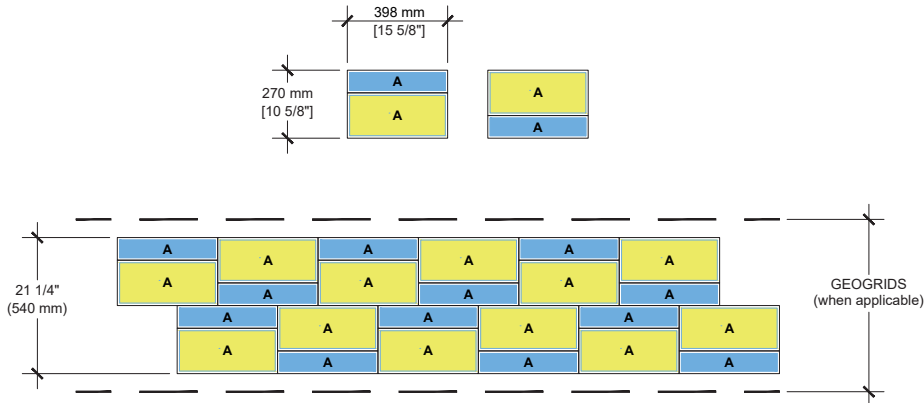

NUMBER OF BLOCKS REQUIRED	MODULE
<b>RAFFINATO</b>	<b>A</b>
<b>67 % of the surface</b> - Raffinato 90 mm	2
<b>33 % of the surface</b> - Raffinato 180 mm	2

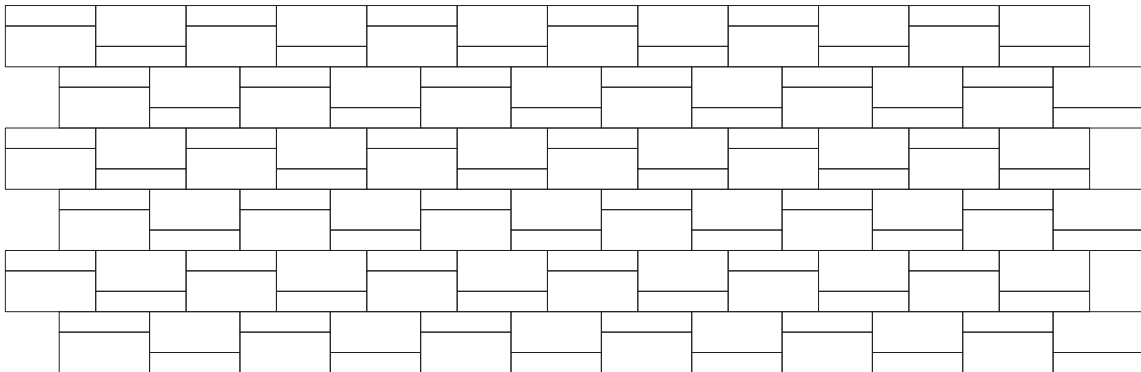

# INSTALLATION GUIDE

## FREESTANDING WALLS - RAFFINATO 90 MM & 180 MM

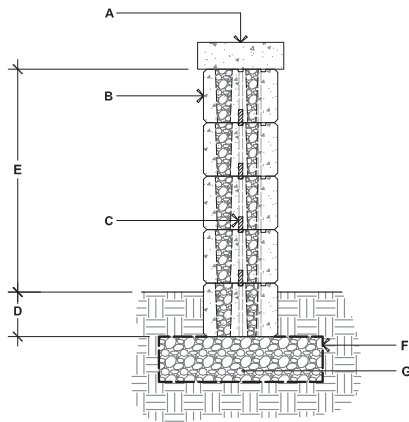

### RAFFINATO 90 mm & 180 mm

- A.** TECO-BLOC CAP UNIT SECURED TO UNIT BELOW WITH CONCRETE ADHESIVE
- B.** RAFFINATO 90 mm AND 180 mm DOUBLE-SIDED WALL UNITS SECURE EACH ROW WITH CONCRETE ADHESIVE
- C.** CONNECTOR
- D.** EMBEDMENT DEPTH, 6" (150 mm) MIN.
- E.** 29 7/16" (750 mm) MAX.
- F.** GEOTEXTILE
- G.** COMPACTED GRANULAR LEVELING PAD, 6" (150 mm) THICK MIN. THICKNESS ACCORDING TO PROJECT SPECIFIC CONDITIONS

## 90° CORNER OF A DOUBLE-SIDED WALL

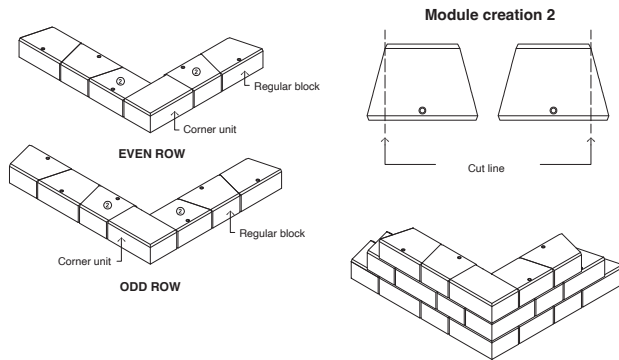

## DOUBLE-SIDED WALL RADIUS

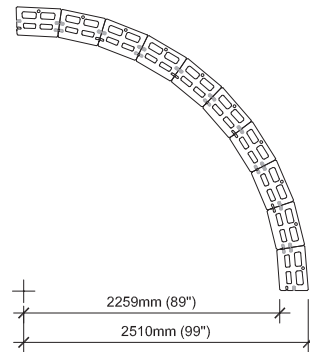

It is the user's responsibility to verify for the quantity of materials required.

## DOUBLE SIDED WALL - END OF A STRAIGHT WALL

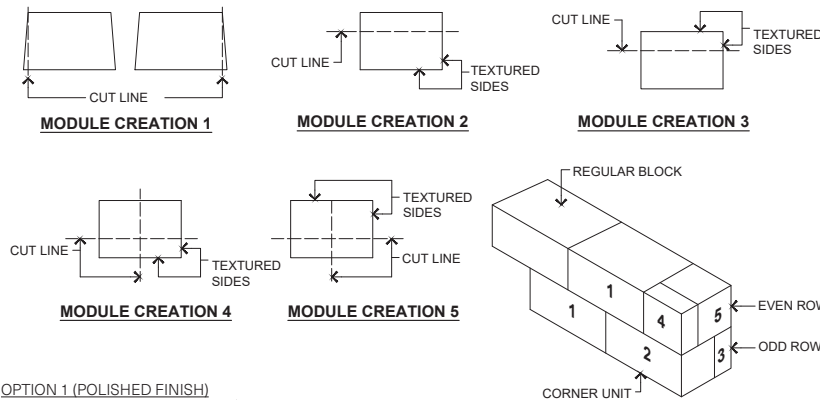

### GENERAL NOTES

1. Alternate odd and even rows.
2. Stagger joints from one row to the next.
3. Glue all modules at each row with concrete adhesive.
4. Cavities, grooves and connectors are not illustrated to avoid overloading the image.

OPTION 1 (POLISHED FINISH)

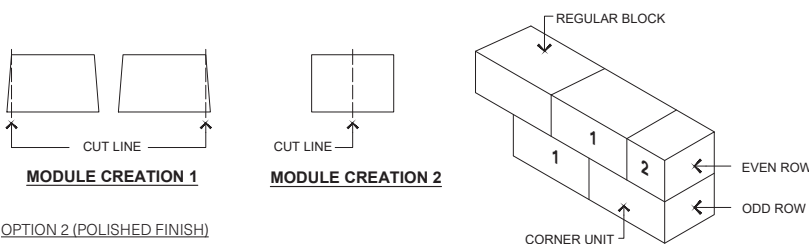

OPTION 2 (POLISHED FINISH)

PLEASE REFER TO P.4 FOR THE CORRECT USE AND LIMITATIONS OF PROVIDED TECHNICAL INFORMATION.

# INSTALLATION GUIDE

## PILLARS - RAFFINATO 90 mm & 180 mm

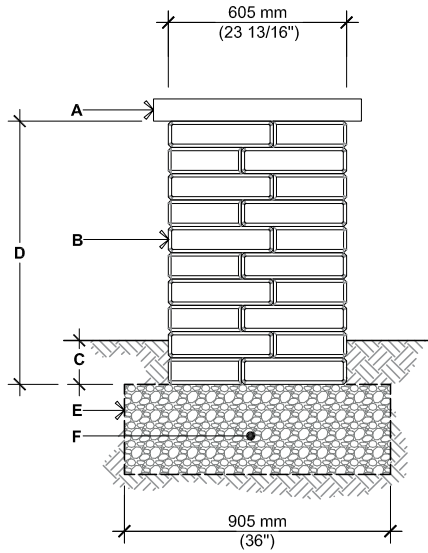

### RAFFINATO 90 mm

- A.** STONEDGE COLLECTION PILLAR CAP UNIT, SECURE TO UNITS BELOW WITH CONCRETE ADHESIVE
- B.** RAFFINATO 90 mm PILLAR UNIT SECURE EACH ROW WITH CONCRETE ADHESIVE
- C.** EMBEDMENT DEPTH: 150 mm (6") MIN.
- D.** 1 080 mm (42 ½"), MAXIMUM HEIGHT
- E.** GEOTEXTILE
- F.** COMPACTED GRANULAR BASE 150 mm (6") THICK MIN. THICKNESS ACCORDING TO PROJECT SPECIFIC CONDITIONS

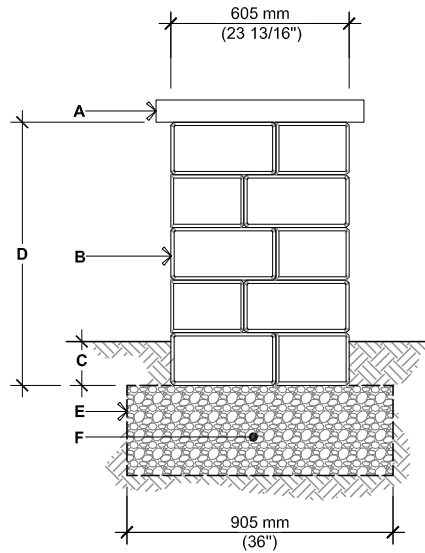

### RAFFINATO 180 mm

- A.** STONEDGE COLLECTION PILLAR CAP UNIT, SECURE TO UNITS BELOW WITH CONCRETE ADHESIVE
- B.** RAFFINATO 180 mm PILLAR UNIT SECURE EACH ROW WITH CONCRETE ADHESIVE
- C.** EMBEDMENT DEPTH: 150 mm (6") MIN.
- D.** 1080 mm (42 ½"), MAXIMUM HEIGHT
- E.** GEOTEXTILE
- F.** COMPACTED GRANULAR BASE 150 mm (6") THICK MIN. THICKNESS ACCORDING TO PROJECT SPECIFIC CONDITIONS

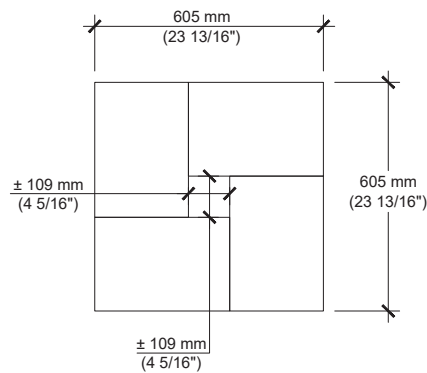

For all possible combinations of pillars and caps, please refer to the correspondence table on page 145

# INSTALLATION GUIDE

## PILLARS - RAFFINATO 90 mm & 180 mm

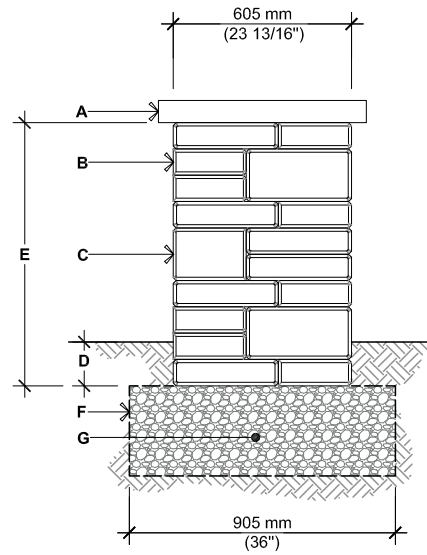
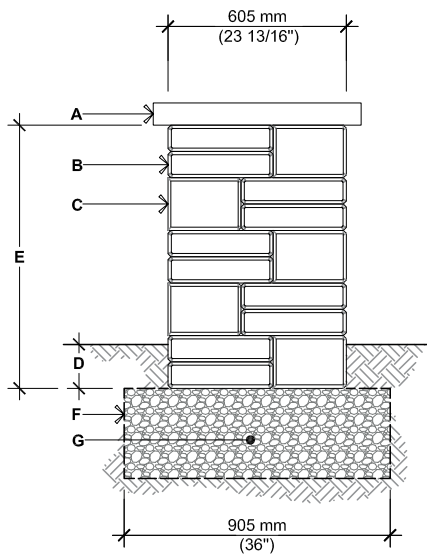

### RAFFINATO 90 mm & 180 mm OPTION A

- A. STONEDGE COLLECTION PILLAR CAP UNIT, SECURE TO UNITS BELOW WITH CONCRETE ADHESIVE
- B. RAFFINATO 90 mm PILLAR UNIT SECURE EACH ROW WITH CONCRETE ADHESIVE
- C. RAFFINATO 180 mm PILLAR UNIT SECURE EACH ROW WITH CONCRETE ADHESIVE
- D. EMBEDMENT DEPTH: 150 mm (6") MIN.
- E. 1 080 mm (42 1/2"), MAXIMUM HEIGHT
- F. GEOTEXTILE
- G. COMPACTED GRANULAR BASE 150 mm (6") THICK MIN. THICKNESS ACCORDING TO PROJECT SPECIFIC CONDITIONS

### RAFFINATO 90 mm & 180 mm OPTION B

- A. STONEDGE COLLECTION PILLAR CAP UNIT, SECURE TO UNITS BELOW WITH CONCRETE ADHESIVE
- B. RAFFINATO 90 mm PILLAR UNIT SECURE EACH ROW WITH CONCRETE ADHESIVE
- C. RAFFINATO 180 mm PILLAR UNIT SECURE EACH ROW WITH CONCRETE ADHESIVE
- D. EMBEDMENT DEPTH: 150 mm (6") MIN.
- E. 1 080 mm (42 1/2"), MAXIMUM HEIGHT
- F. GEOTEXTILE
- G. COMPACTED GRANULAR BASE 150 mm (6") THICK MIN. THICKNESS ACCORDING TO PROJECT SPECIFIC CONDITIONS

## STEPS

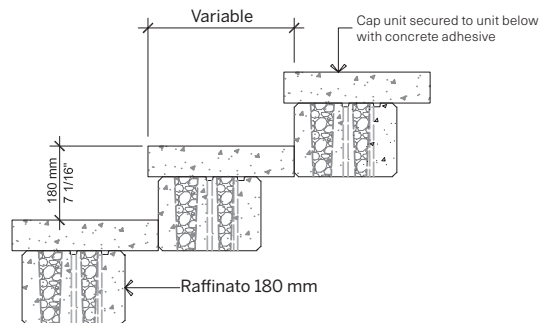
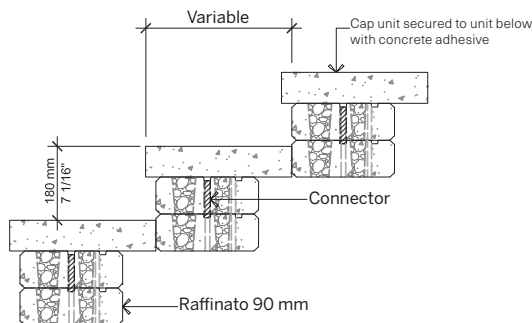

For all possible combinations of pillars and caps, please refer to the correspondence table on page 145

Check with your local Building Codes to determine any restrictions or guidelines regarding the dimensions of steps (including riser height and step tread) as well as handrail specifications.

PLEASE REFER TO P.4 FOR THE CORRECT USE AND LIMITATIONS OF PROVIDED TECHNICAL INFORMATION.

# INSTALLATION GUIDE

## GRILL ISLAND - RAFFINATO SMOOTH 90 mm & 180 mm

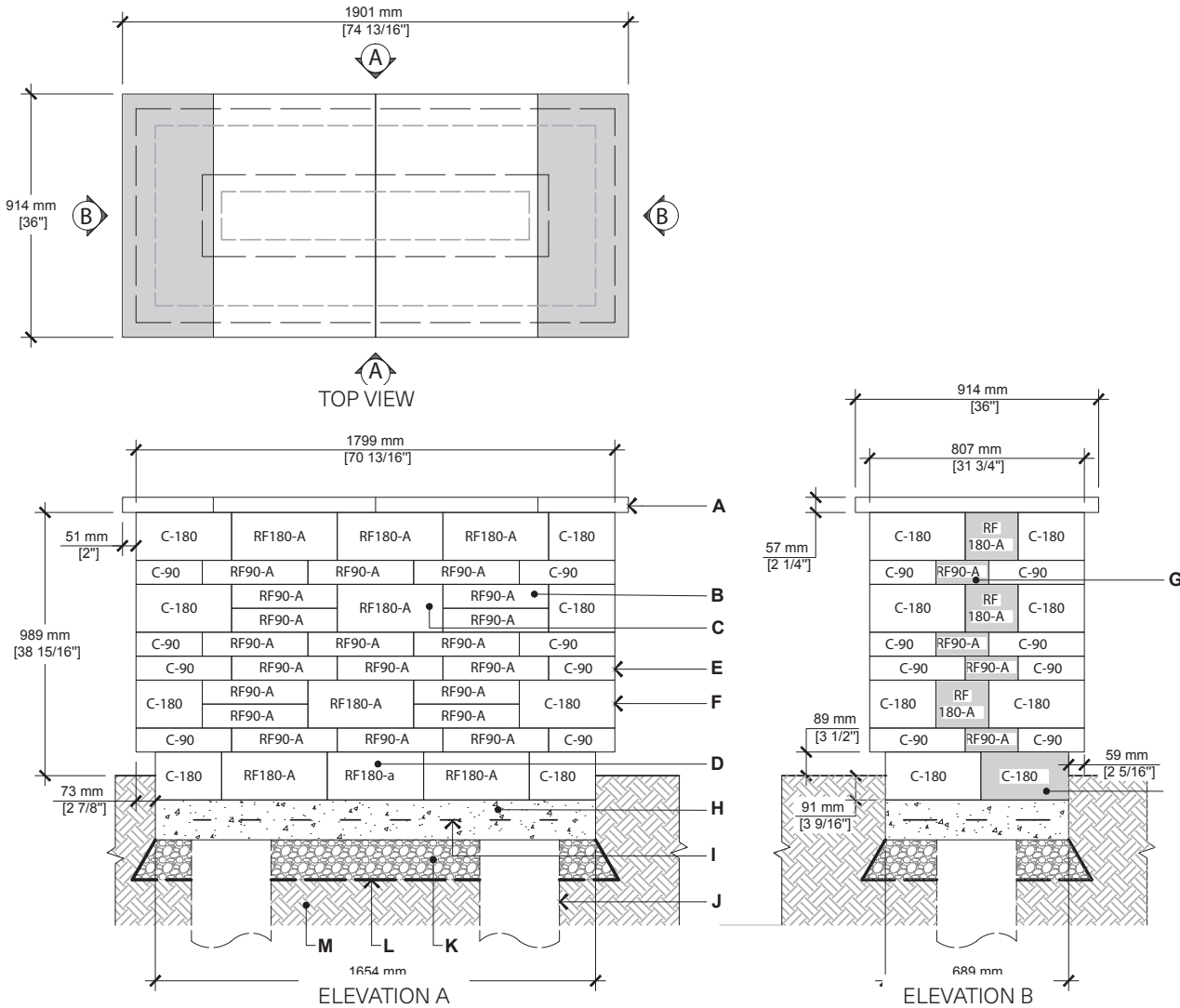

- A.** YORK COUNTER TOP 24" x 36" x 2 1/4" (CUT ON FIELD AS REQUIRED)
- B.** RAFFINATO 90 mm UNIT (A) – LONG FACE EXPOSED (SHOWN WITH UPPERCASE LETTER)
- C.** RAFFINATO 180 mm UNIT (A) – LONG FACE EXPOSED (SHOWN WITH UPPERCASE LETTER)
- D.** RAFFINATO 180 mm UNIT (A) – SHORT FACE EXPOSED (SHOWN WITH LOWERCASE LETTER)
- E.** RAFFINATO 90 mm PILLAR UNIT
- F.** RAFFINATO 180 mm PILLAR UNIT
- G.** RAFFINATO UNIT CUT ON FIELD AS REQUIRED
- H.** CAST IN PLACE CONCRETE SLAB 4350 psi (30 MPa), 5" (125 mm) THICK
- I.** 4X4-4/4 (102X102-MW25.8XMW25.8) WELDED WIRE MESH AND/OR REBAR AS PER SITE CONDITIONS
- J.** 12" (300 mm) DIA. CONCRETE PILLAR, AS PER LOCAL CODE
- K.** 3/4" (20 mm) CLEAN STONE  
6" (150 mm) THICK MIN. AS PER SITE CONDITIONS
- L.** GEOTEXTILE
- M.** NATURAL SOIL OR COMPACTED BACKFILL

### QUANTITY OF MATERIALS REQUIRED

- York Counter top 24" x 36" x 2 1/4": **4**
- Raffinato 90 mm wall unit: **48 A**
- Raffinato 180 mm wall unit: **22 A**
- Raffinato 90 mm pillar unit: **16**
- Raffinato 180 mm pillar unit: **16**

**NOTE:** Appliances and utilities may vary for each project and are not shown on this drawing. This drawing is shown for inspiration only and surplus or shortage of materials may result. It is the user's responsibility to verify for the quantity of materials required. Secure the blocks using a heat resistant concrete adhesive. The installer must ensure that the installation and use of the grill island comply with local regulations and code requirements. Concrete pillars extending to frost line may be required as per local code. Check your local building code before installing.

# INSTALLATION GUIDE

## GRILL ISLAND - RAFFINATO POLISHED 90 mm & 180 mm

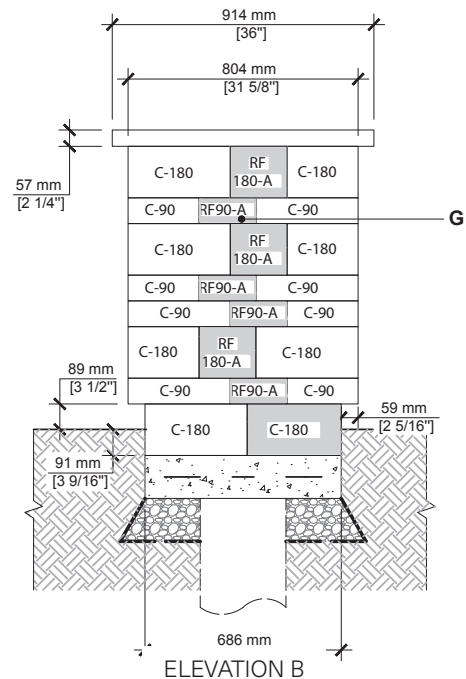
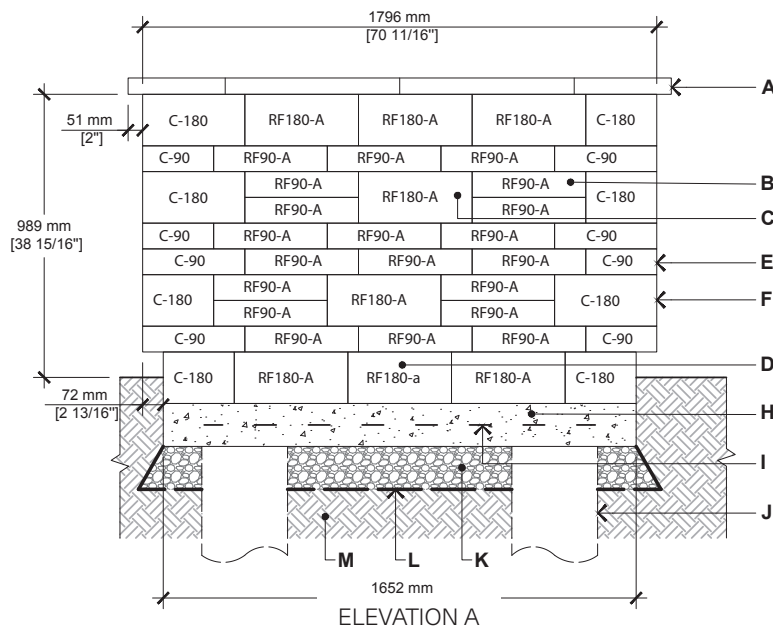
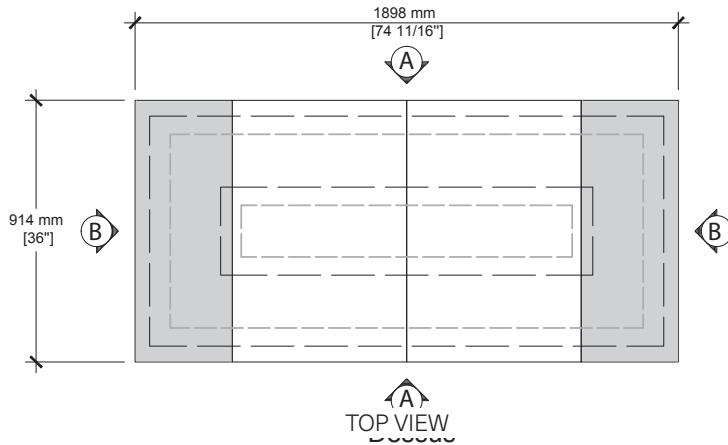

- A. YORK COUNTER TOP 24" x 36" x 2 1/4" (CUT ON FIELD AS REQUIRED)
- B. RAFFINATO 90 mm UNIT (A) – LONG FACE EXPOSED (SHOWN WITH UPPERCASE LETTER)
- C. RAFFINATO 180 mm UNIT (A) – LONG FACE EXPOSED (SHOWN WITH UPPERCASE LETTER)
- D. RAFFINATO 180 mm UNIT (A) – SHORT FACE EXPOSED (SHOWN WITH LOWERCASE LETTER)
- E. RAFFINATO 90 mm PILLAR UNIT
- F. RAFFINATO 180 mm PILLAR UNIT
- G. RAFFINATO UNIT CUT ON FIELD AS REQUIRED
- H. CAST IN PLACE CONCRETE SLAB 4350 psi (30 MPa), 5" (125 mm) THICK
- I. 4X4-4/4 (102X102-MW25.8XMW25.8) WELDED WIRE MESH AND/OR REBAR AS PER SITE CONDITIONS
- J. 12" (300 mm) DIA. CONCRETE PILLAR, AS PER LOCAL CODE
- K. 3/4" (20 mm) CLEAN STONE  
6" (150 mm) THICK MIN. AS PER SITE CONDITIONS
- L. GEOTEXTILE
- M. NATURAL SOIL OR COMPACTED BACKFILL

### QUANTITY OF MATERIALS REQUIRED



- York Counter top 24" x 36" x 2 1/4": **4**
- Raffinato 90 mm wall unit: **48 A**
- Raffinato 180 mm wall unit: **22 A**
- Raffinato 90 mm pillar unit: **16**
- Raffinato 180 mm pillar unit: **16**

**NOTE:** Appliances and utilities may vary for each project and are not shown on this drawing. This drawing is shown for inspiration only and surplus or shortage of materials may result. It is the user's responsibility to verify for the quantity of materials required. Secure the blocks using a heat resistant concrete adhesive. The installer must ensure that the installation and use of the grill island comply with local regulations and code requirements. Concrete pillars extending to frost line may be required as per local code. Check your local building code before installing.



# RÖCKA

DESCRIPTION: Wall & edge double-sided TEXTURE: Fossil stone

Specifications per pallet		Imperial	Metric
<b>A</b> 	Dimension Top (L×D×H) <b>A</b>	13 ¼ × 7 ¾ × 6	337 × 197 × 152
	Dimension Bottom (L×D×H) <b>A</b>	13 ¼ × 8 × 6	337 × 203 × 152
	8 units / pallet		
<b>B</b> 	Dimension Top (L×D×H) <b>B</b>	26 ½ × 7 ¾ × 6	673 × 197 × 152
	Dimension Bottom (L×D×H) <b>B</b>	26 ½ × 8 × 6	673 × 203 × 152
	8 units / pallet		
<b>C</b> 	Dimension Top (L×D×H) <b>C</b>	39 ¾ × 7 ¾ × 6	1 010 × 197 × 152
	Dimension Bottom (L×D×H) <b>C</b>	39 ¾ × 8 × 6	1 010 × 203 × 152
	Cubing	19.88 ft <sup>2</sup>	1.85 m <sup>2</sup>
	Approx. Weight	1 860 lbs	844 kg
	Number of rows	3	
	Coverage per row	6.63 ft <sup>2</sup>	0.62 m <sup>2</sup>
	Coverage per unit <b>A</b>	0.55 ft <sup>2</sup>	0.05 m <sup>2</sup>
	Coverage per unit <b>B</b>	1.10 ft <sup>2</sup>	0.10 m <sup>2</sup>
	Coverage per unit <b>C</b>	1.66 ft <sup>2</sup>	0.15 m <sup>2</sup>

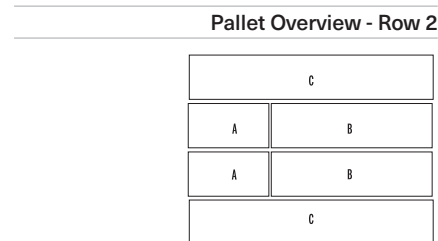
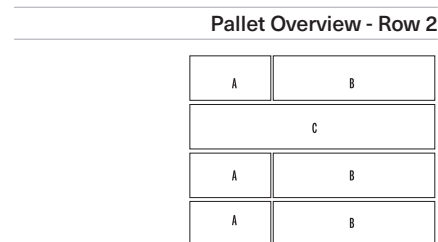
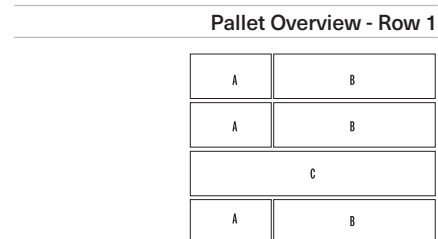
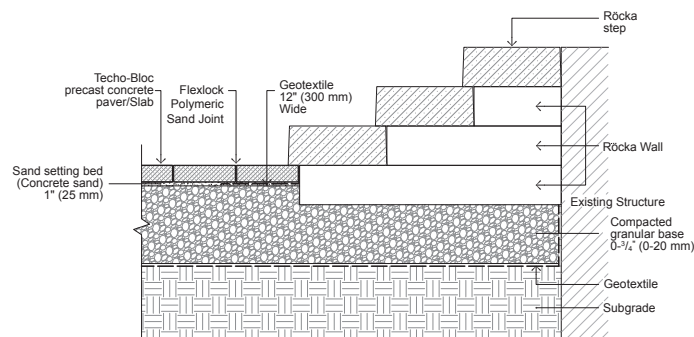

## NOTES

See page 6 for icons description.

\*For an authentic look, each color option is composed of a variety of darker & lighter tones. Natural ingredients such as granite are present within the recipe to allow for a range in tones, veining and textures from one stone to another.

See page 146 to 161 for more technical information.

The dimensional tolerance for Stonedge wet cast retaining wall units is: ± 3/16" (5 mm) for height and ± 1/2" (13 mm) for length and width. During the installation, the level between adjacent wall units will vary (usually more than for a dry cast wall unit) in order to obtain a more realistic appearance of a natural stone wall.

# INSTALLATION GUIDE

## FREESTANDING WALLS - RÖCKA

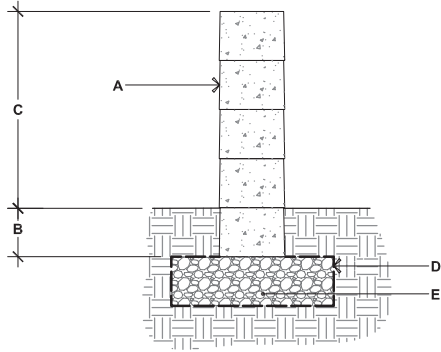

### RÖCKA

- A.** RÖCKA DOUBLE-SIDED WALL UNITS SECURE EACH ROW WITH CONCRETE ADHESIVE
- B.** EMBEDMENT DEPTH, 6" (150 mm) MIN.
- C.** 24" (612 mm) MAX.
- D.** GEOTEXTILE
- E.** COMPACTED GRANULAR LEVELING PAD, 6" (150 mm) THICK MIN. THICKNESS ACCORDING TO PROJECT SPECIFIC CONDITIONS

## 90° CORNER OF A DOUBLE-SIDED WALL

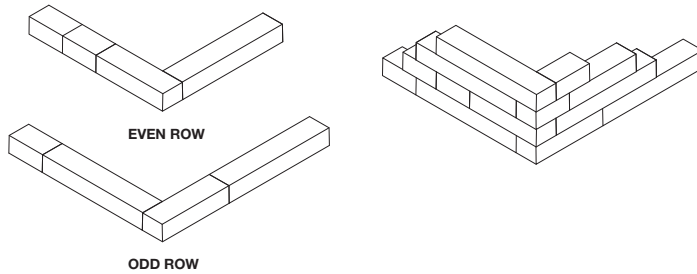

1. Alternate odd and even rows
2. Stagger vertical joints by at least  $\frac{1}{4}$  of the length of the block.
3. Glue all modules at each row with concrete adhesive.
4. It is possible to alternate the blocks (A, B or C) in the same row to create different patterns.

## DOUBLE-SIDED WALL - END OF A STRAIGHT WALL

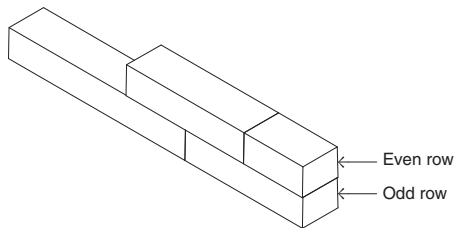

\* It is possible to alternate the blocks (A, B or C) in the same row to create different patterns. However, a minimum distance of  $\frac{1}{4}$  the length of the block is required between the vertical joints.

# INSTALLATION GUIDE

## GRILL ISLAND - RÖCKA

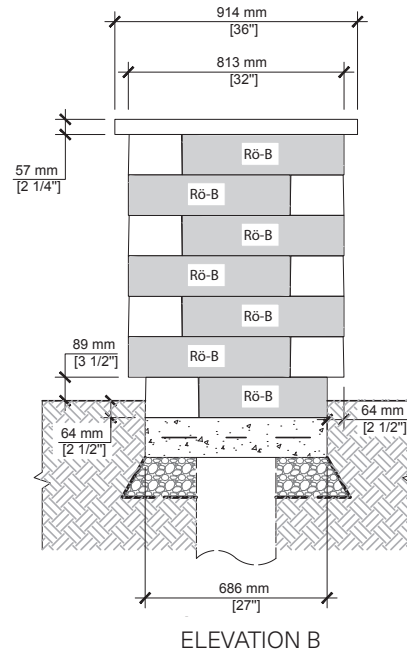
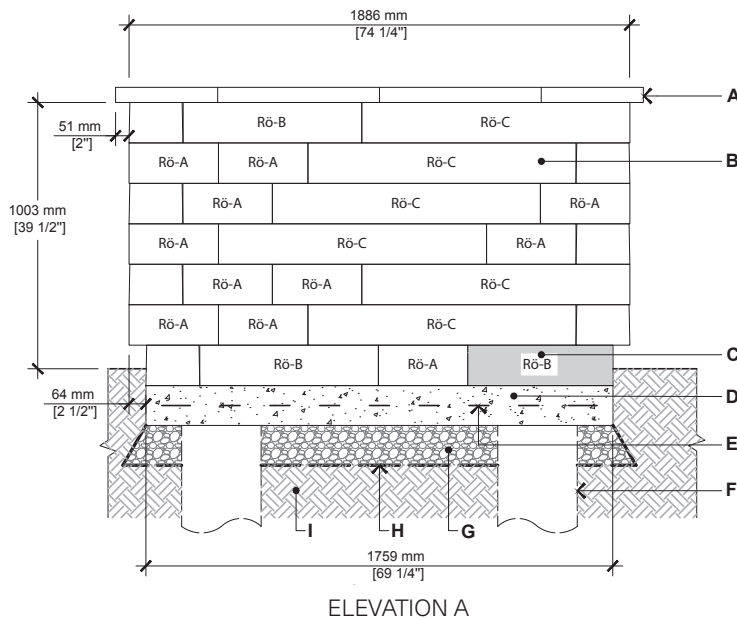
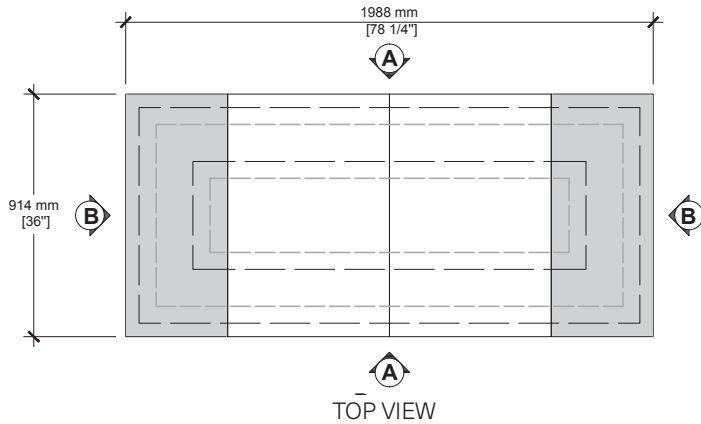

- A. YORK COUNTER TOP 24" X 36" X 2 1/4" (CUT ON FIELD AS REQUIRED)
- B. RÖCKA WALL UNIT (A, B OR C)
- C. RÖCKA WALL UNIT CUT ON FIELD AS REQUIRED
- D. CAST IN PLACE CONCRETE SLAB 4350 psi (30 MPa), 5" (125 mm) THICK
- E. 4X4-4/4 (102X102-MW25.8XMW25.8) WELDED WIRE MESH AND/OR REBAR AS PER SITE CONDITIONS
- F. 12" (300 mm) DIA. CONCRETE PILLAR, AS PER LOCAL CODE
- G. 3/4" (20 mm) CLEAN STONE
- H. GEOTEXTILE
- I. NATURAL SOIL OR COMPACTED BACKFILL

### QUANTITY OF MATERIALS REQUIRED

- York Counter top 24" x 36" x 2 1/4": **4**
- Röcka wall unit: **22 A, 20 B, 12 C**

**NOTE:** Appliances and utilities may vary for each project and are not shown on this drawing. This drawing is shown for inspiration only and surplus or shortage of materials may result. It is the user's responsibility to verify for the quantity of materials required. Secure the blocks using a heat resistant concrete adhesive. The installer must ensure that the installation and use of the grill island comply with local regulations and code requirements. Concrete pillars extending to frost line may be required as per local code. Check your local building code before installing.



# SANDSTONE

**DESCRIPTION:** Thinset Veneer Wall **TEXTURE:** Natural Stone

## Box Overview

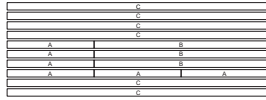



Natural Stone

Beige

Natural Stone

Grey

## Specifications per pallet

		Imperial	Metric
<b>A</b>		Product dimension (L x D x H) <b>A</b> 7 7/8 x 1 1/8 x 3 15/16	200 x 17 x 100
	120 units / pallet	Product dimension (L x D x H) <b>B</b> 15 3/4 x 1 1/8 x 3 15/16	400 x 17 x 100
<b>B</b>		Product dimension (L x D x H) <b>C</b> 23 5/8 x 1 1/8 x 3 15/16	600 x 17 x 100
	60 units / pallet	Cubing*	20 boxes 20 boxes
		Approx. Weight	1 261 lbs 572 kg
<b>C</b>		Coverage per box*	7.28 ft <sup>2</sup> 0.68 m <sup>2</sup>
	120 units / pallet	Lin. coverage per box*	20.18 lin. ft 6.15 lin. m

## NOTES

See page 6 for icons description.

### COMPATIBLE CAPS

See page 145 for product compatibility.

See page 146 to 161 for more technical information.

\*Cubing including 3/8" (10 mm) joint width

### NATURAL STONE COLLECTION

Natural stones are products of nature. They are sold as is and are not covered by Techo-Bloc's Warranty. Installation is deemed acceptance of products.

# INSTALLATION GUIDE

## THINSET VENEER WALL - SANDSTONE

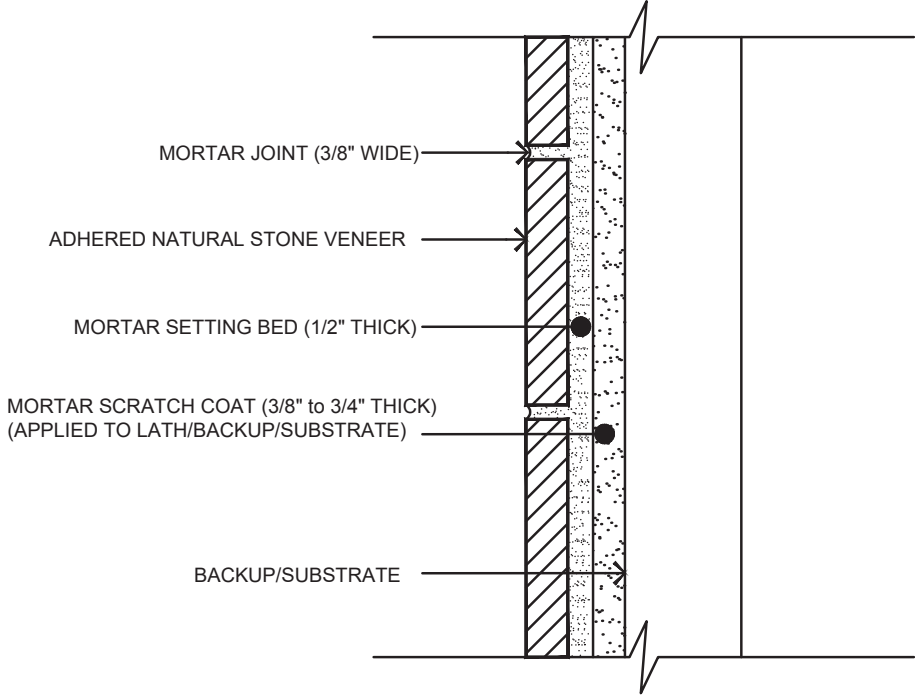



D 

P **PATENT**  
CND 2,114,677  
US 5,528,873

# SEMMA

**DESCRIPTION:** Wall double-sided **TEXTURE:** Split Face

## Pallet Overview

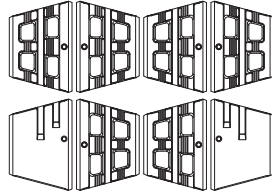

Split Face  
Chestnut Brown

Split Face  
Sandalwood

Split Face  
Champlain Grey

Split Face  
Shale Grey

## Specifications per pallet

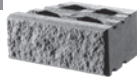
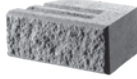
	Imperial	Metric
<b>A</b>  REGULAR 30 units / pallet	Dimension Front (L x D x H) <b>A</b> 16 x 11 x 5 7/8	406 x 279 x 150
	Dimension Back (L x D x H) <b>A</b> 10 1/2 x 11 x 5 7/8	266 x 279 x 150
	Dimension Front (L x D x H) <b>B</b> 16 x 11 x 5 7/8	406 x 279 x 150
	Dimension Back (L x D x H) <b>B</b> 10 1/2 x 11 x 5 7/8	266 x 279 x 150
<b>B</b>  CORNER 10 units / pallet	Cubing	40 units / 2.44 m <sup>2</sup>
	Approx. Weight	2 363 lbs / 1 072 kg
	Number of rows	5
	Coverage per row	5.25 ft <sup>2</sup> / 0.49 m <sup>2</sup>
	Lin. coverage per row	10.67 lin. ft / 3.25 lin. m

## NOTES

See page 6 for icons description.

### COMPATIBLE CAPS

See page 145 for product compatibility.

When building a double-sided wall one pallet will cover an average of 21.74 ft<sup>2</sup>.

The corner units for the Semma block should be glued with a concrete adhesive.

The corner unit can be used as a right or left corner unit and as a regular unit. Metric measures are approximate.

See page 146 to 161 for more technical information.

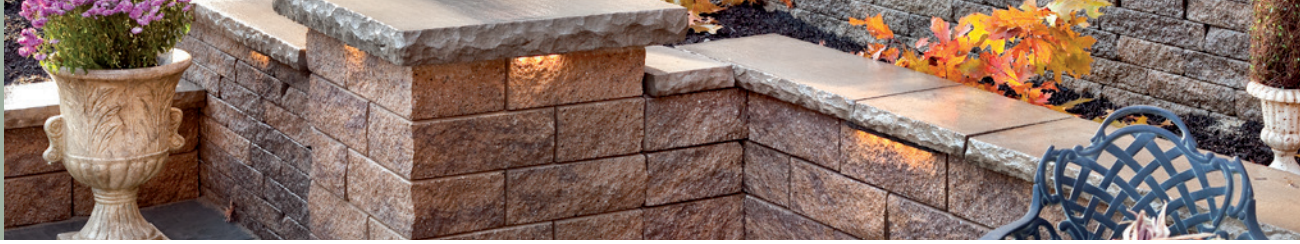

D ❄️

# SEMMA

**DESCRIPTION:** Corner or Pillar **TEXTURE:** Split Face

90 mm

**Specifications per pallet**

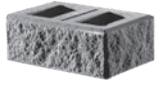

24 units / pallet  
12 right corners  
12 left corners

	Imperial	Metric
Product dimension (L x D x H)	16 x 10 1/2 x 5 7/8	406 x 266 x 150
Cubing	24 units	24 units
Approx. Weight	1 403 lbs	636 kg
Number of rows	4	
Pillar height	35 7/8 in	900 mm

**Pallet Overview**

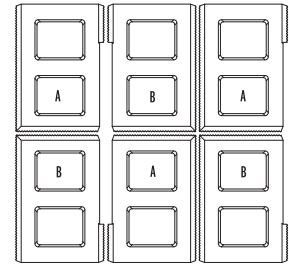

Chestnut Brown  
Sandlewood  
Champlain Grey  
Shale Grey

Split Face  
Split Face  
Split Face  
Split Face



## NOTES

See page 6 for icons description.

**COMPATIBLE CAPS**

See page 145 for product compatibility.

See page 146 to 161 for more technical information.

CLEAN SAND/GRAVEL/ SAND AND GRAVEL MIXES ( $\phi=34^\circ$ ,  $\gamma = 120$  pcf)  
GEOGRID: MIRAGRID 3XT BY TENCATE (RFd=1.10, RFcr=1.45, RFid=1.25, Cds=0.9, Ci=0.9)

**CASE N° 1 :**  
No Surcharge  
No Backslope  
No Toe Slope

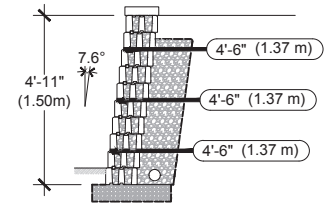
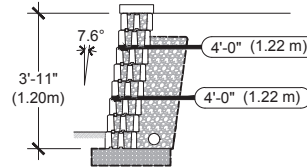
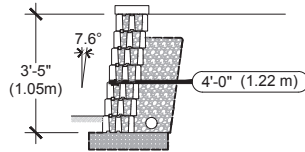
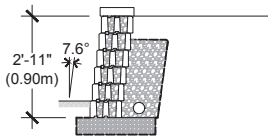

VISIT [WWW.TECHO-BLOC.COM](http://WWW.TECHO-BLOC.COM) FOR COMPLETE DESIGN CHART DOCUMENT  
(USA AND CANADA VERSIONS)

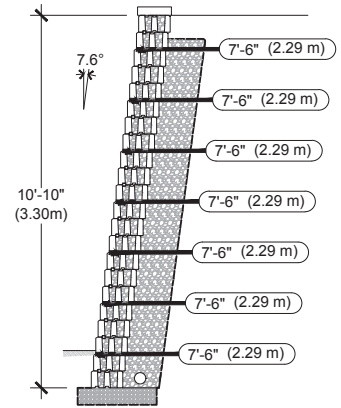
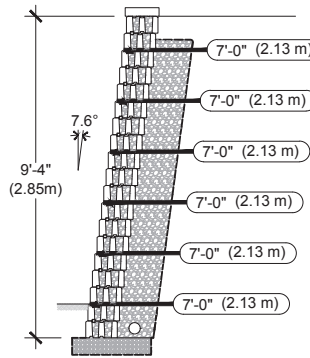
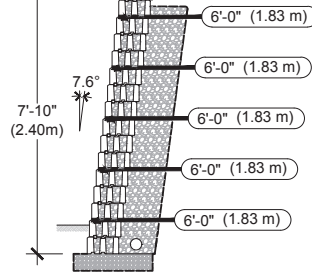
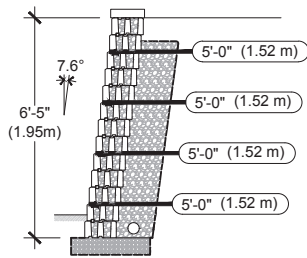

1. The information contained in the design charts is supplied for information purposes only and as such should only be used for preliminary designs.
2. The height (H) of the wall is the total height from the leveling pad to the top of the wall not including the thickness of the cap.
3. Soil parameters: reinforced soil ( $\phi = 34^\circ$ ,  $\gamma = 120$  pcf); retained soil ( $\phi = 34^\circ$ ,  $\gamma = 120$  pcf); foundation soil ( $\phi = 34^\circ$ ,  $\gamma = 120$  pcf)
4. A qualified engineer should be consulted for the final design to be used for construction.
5. The foundation soil must be able to support the wall system. The bearing capacity of the foundation soil, settlement, and global stability must be verified and validated by a qualified geotechnical engineer.
6. The seismic analysis is not included.
7. The design charts do not apply to tiered walls.
8. The charts assume that the walls are constructed in accordance with Techo-Bloc specifications, good construction practice and an adequate drainage system.
9. The geogrid layout has been optimized to satisfy the design requirements of the NCMA's Design Manual for Segmental Retaining Walls, 3rd Edition.
10. The minimum burial depth must be 6 in (150 mm) or 10% of the exposed height, whichever is greater.
11. Engineering judgement should be used when interpolating between heights.
12. Techo-Bloc and its predecessors, successors, beneficiaries, employees, associates, administrators and insurers accepts no liability for the incorrect use of information contained in the design charts.
13. For further information, please contact our technical service department.

# INSTALLATION GUIDE

## FREESTANDING WALLS - SEMMA

### SEMMA

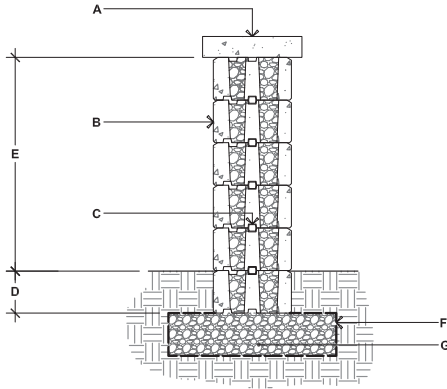

- A. TECO-BLOC CAP UNIT SECURED TO UNIT BELOW WITH CONCRETE ADHESIVE
- B. SEMMA DOUBLE-SIDED WALL UNIT SECURE EACH ROW WITH CONCRETE ADHESIVE
- C. CONNECTOR
- D. EMBEDMENT DEPTH, 6" (150 mm) MIN.
- E. 29 7/16" (750 mm) MAX.
- F. GEOTEXTILE
- G. COMPACTED GRANULAR LEVELING PAD, 6" (150 mm) THICK MIN. THICKNESS ACCORDING TO PROJECT SPECIFIC CONDITIONS

## 90° CORNER OF A DOUBLE-SIDED WALL

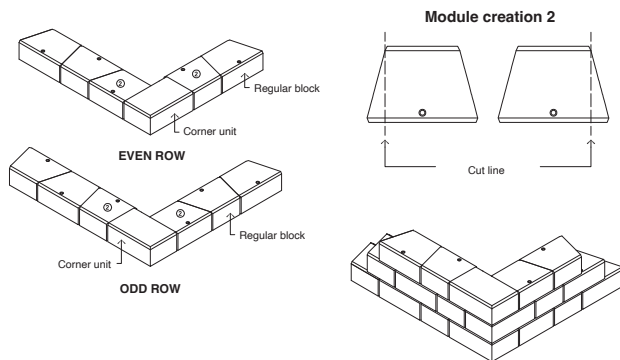

## DOUBLE-SIDED WALL RADIUS

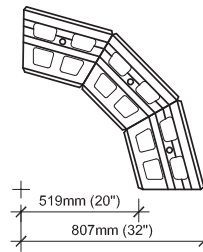

It is the user's responsibility to verify for the quantity of materials required.

## DOUBLE-SIDED WALL - END OF A STRAIGHT WALL

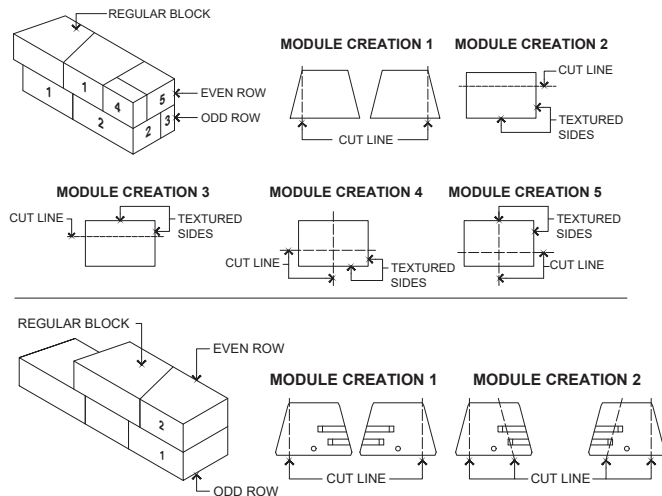

### GENERAL NOTES

1. Alternate odd and even rows.
2. Stagger joints from one row to the next.
3. Glue all modules at each row with concrete adhesive.
4. Cavities, grooves and connectors are not illustrated to avoid overloading the image.

# INSTALLATION GUIDE

## PILLARS - SEMMA

### SEMMA

- A. PILLAR CAP UNIT (SECURE WITH CONCRETE ADHESIVE)
- B. SEMMA PILLAR UNIT SECURE EACH ROW WITH CONCRETE ADHESIVE
- C. EMBEDMENT 6" (150 mm) MIN.
- D. 35 7/8" (900 mm), HEIGHT PER PALLET 47 1/4" (1200 mm), MAXIMUM HEIGHT
- E. GEOTEXTILE
- F. COMPACTED GRANULAR BASE 6" (150mm) THICK MIN. THICKNESS ACCORDING TO PROJECT SPECIFIC CONDITIONS

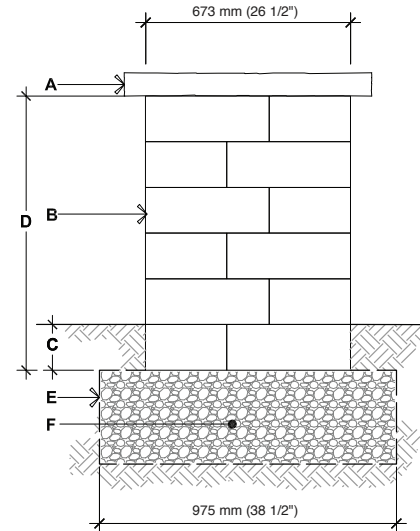

## STEPS

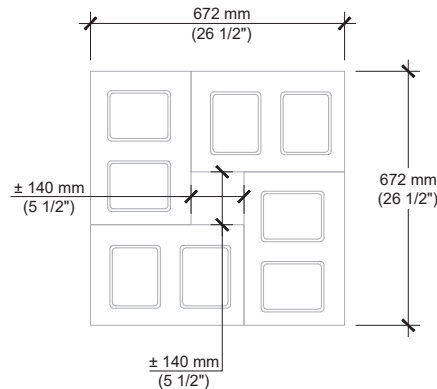
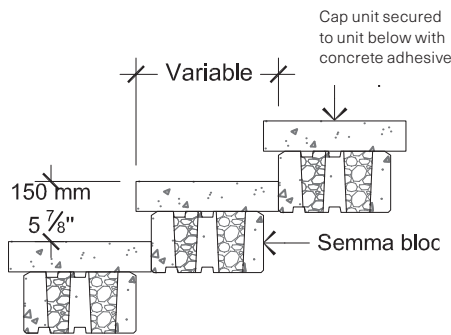

**For all possible combinations of pillars and caps, please refer to the correspondence table on page 145.**

Check with your local Building Codes to determine any restrictions or guidelines regarding the dimensions of steps (including riser height and step tread) as well as handrail specifications.

## GRAVITY AND REINFORCED WALLS - SEMMA

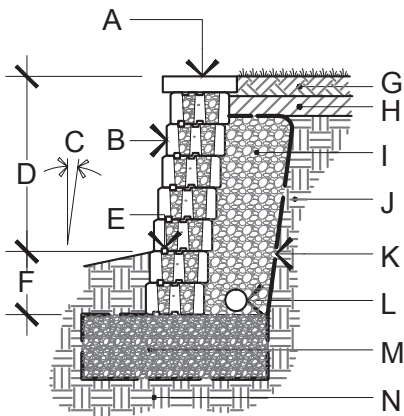

### GRAVITY WALL DETAIL

- A. CAP FROM TECO-BLOC
- B. SEMMA BLOCK FROM TECO-BLOC
- C. WALL INCLINATION (7.6°)
- D. EXPOSED HEIGHT
- E. HDPE HORIZONTAL KEY
- F. EMBEDMENT DEPTH
- G. TOP SOIL
- H. LOW PERMEABILITY SOIL
- I. 3/4" (20 mm) CLEAN STONE, 13" (330 mm) THICK MIN.

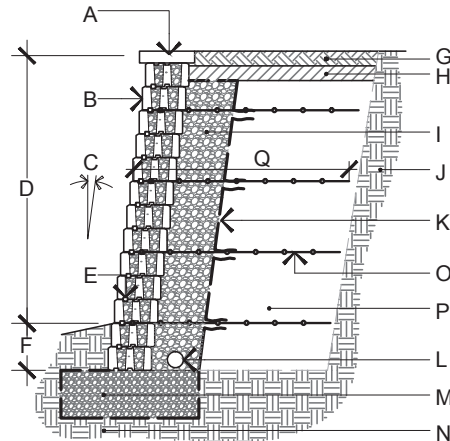

### REINFORCED WALL DETAIL

- J. RETAINED SOIL
- K. GEOTEXTILE
- L. PERFORATED DRAIN
- M. LEVELING PAD
- N. FOUNDATION SOIL
- O. GEOGRID
- P. REINFORCED SOIL
- Q. GEOGRID LENGTH

# INSTALLATION GUIDE

## FIREPIT - SEMMA

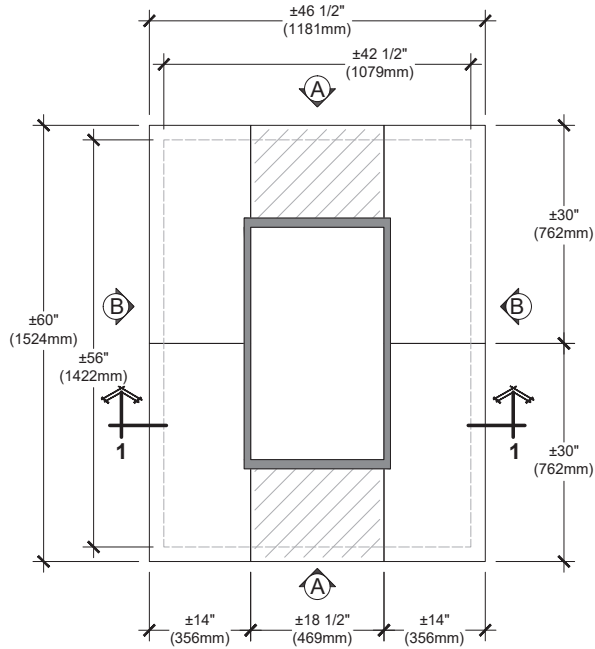

TOP

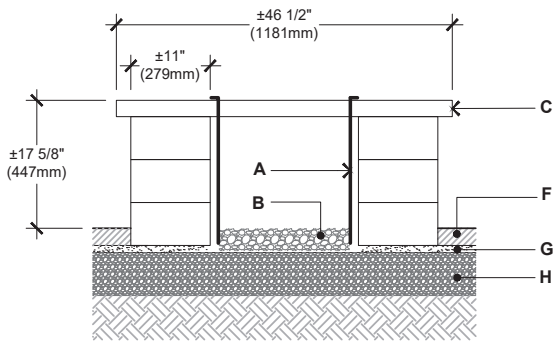

SECTION 1-1

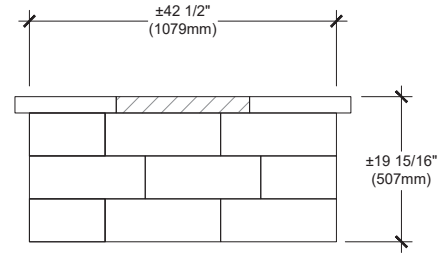

ELEVATION A

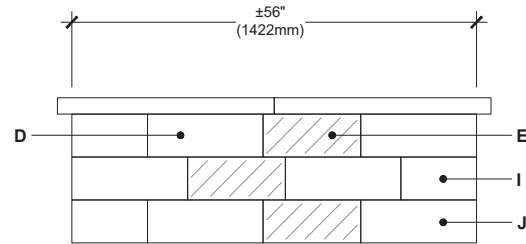

ELEVATION B

 CUT ON FIELD

- A. STEEL BOX INSERT
- B. CLEAN STONE 3/4" (20 mm), 4" (100 mm) THICK
- C. PIEDIMONTE CAP 14"X30" (CUT ON FIELD AS REQUIRED)
- D. SEMMA BLOCK (A OR B UNIT)
- E. SEMMA BLOCK (A OR B UNIT) CUT ON FIELD AS REQUIRED
- F. TECHO-BLOC PAVERS OR SLABS
- G. SETTING BED 1" (25 mm)
- H. COMPACTED GRANULAR 0- 3/4" (0-20 mm)
- I. SEMMA PILLAR UNIT (LEFT CORNER)
- J. SEMMA PILLAR (RIGHT CORNER)

### QUANTITY OF MATERIALS REQUIRED

- Piedimonte Cap (14"x30"): 6
- Semma (A or B): 24
- Semma Pillar: 12 (8 RIGHT CORNER, 4 LEFT CORNERS)

NOTE: Secure the blocks using a heat resistant concrete adhesive. The installer must ensure that the installation and use of the firepit comply with local regulations and code requirements.



# SKYSCRAPER

DESCRIPTION: Wall TEXTURE: Smooth

## Pallet Overview - Top unit

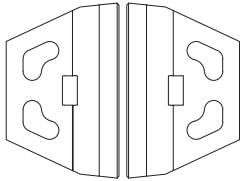

## Pallet Overview - Middle unit

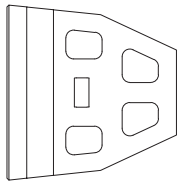

## Pallet Overview - Corner unit

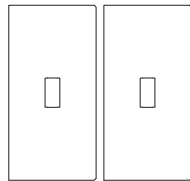

Smooth

Chestnut Brown



Smooth

Shale Grey

## TOP UNIT

### Specifications per pallet

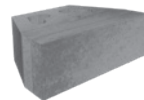

4 units / pallet

	Imperial	Metric
Dimension Front (L x D x H)	36 x 23 1/4 x 12	914 x 590 x 305
Dimension Back (L x D x H)	20 3/8 x 23 1/4 x 12	513 x 590 x 305
Cubing	12.00 ft <sup>2</sup>	1.11 m <sup>2</sup>
	12.00 lin ft	3.66 lin m
Approx. Weight	2 100 lbs	953 kg
Number of rows	2	
Coverage per row	6.00 ft <sup>2</sup>	0.56 m <sup>2</sup>
Linear coverage per row	6.00 lin ft	1.83 lin m

## MIDDLE UNIT

### Specifications per pallet



2 units / pallet

	Imperial	Metric
Dimension Front (L x D x H)	36 x 34 7/8 x 12	914 x 886 x 305
Dimension Back (L x D x H)	17 1/2 x 34 7/8 x 12	444 x 886 x 305
Cubing	6.00 ft <sup>2</sup>	0.56 m <sup>2</sup>
	6.00 lin ft	1.83 lin m
Approx. Weight	1 620 lbs	735 kg
Number of rows	2	
Coverage per row	3.00 ft <sup>2</sup>	0.28 m <sup>2</sup>
Linear coverage per row	3.00 lin ft	0.91 lin m

## CORNER UNIT

### Specifications per pallet



4 units / pallet

	Imperial	Metric
Product dimension (L x D x H)	36 x 18 x 12	914 x 457 x 305
Cubing	4 units	4 units
Approx. Weight	2 460 lbs	1 116 kg
Number of rows	2	

## NOTES

See page 6 for icons description.

### COMPATIBLE CAPS

See page 145 for product compatibility.

Clamp or Mechanical tool available for machine installation. Check with your local Techo-Bloc representative for more information.

See page 146 to 161 for more technical information.



# SKYSCRAPER

DESCRIPTION: Wall TEXTURE: Smooth

## BASE UNIT

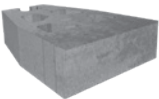
Specifications per pallet		Imperial	Metric
	Dimension Front (L x D x H)	36 x 48 1/8 x 12	914 x 1220 x 305
	Dimension Back (L x D x H)	17 5/8 x 48 1/8 x 12	440 x 1220 x 305
2 units / pallet	Cubing	6.00 ft <sup>2</sup>	0.56 m <sup>2</sup>
		6.00 lin ft	1.83 lin m
	Approx. Weight	1 860 lbs	844 kg
	Number of rows	2	
	Coverage per row	3.00 ft <sup>2</sup>	0.28 m <sup>2</sup>
	Linear coverage per row	3.00 lin ft	0.91 lin m

## EXTENDER UNIT

Specifications per pallet		Imperial	Metric
	Product dimension (L x D x H)	20 1/2 x 24 3/8 x 12	520 x 619 x 305
	Cubing	4 units	4 units
4 units / pallet	Approx. Weight	1 800 lbs	816 kg
	Number of rows	2	

## Pallet Overview - Base unit

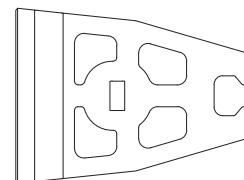

## Pallet Overview - Extender unit

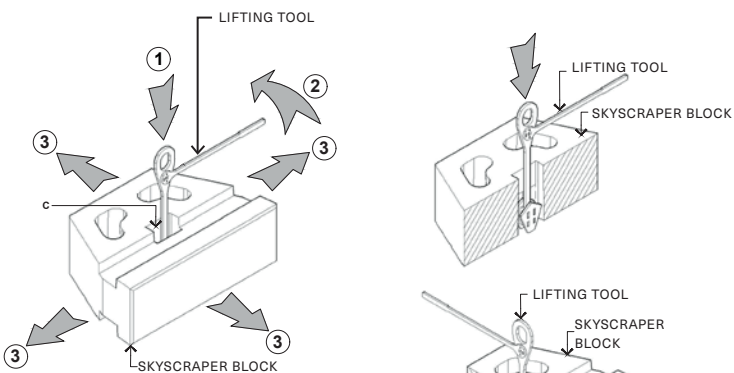
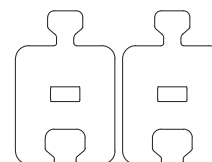

NOTE:  
 1. INSERT TECO-BLOC LIFTING TOOL INTO THE LIFTING CAVITY.  
 2. TURN THE LIFTING TOOL TO LOCK THE SYSTEM.  
 3. MOVE AND INSTALL BLOCK AS REQUIRED.  
 4. USE EQUIPMENT AND RIGGING CONFORMING TO LOCAL CODES AND CAPABLE OF LIFTING EACH UNIT WEIGHT.

Chestnut Brown

Smooth



Shale Grey

Smooth



## NOTES

See page 6 for icons description.

### COMPATIBLE CAPS

See page 145 for product compatibility.

See page 146 to 161 for more technical information.

### ALLOWABLE STRESS DESIGN

CLEAN SAND/ SAND AND GRAVEL MIXES ( $\phi=34^\circ$ ,  $\gamma = 130$  pcf)

**CASE N° 1 :**  
No Surcharge  
No Backslope  
No Toe Slope

**5 ft (1.52 m) Total Height**  
T: 5

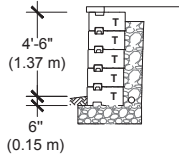

**6 ft (1.83 m) Total Height**  
T: 5  
M: 1

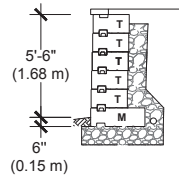

**7 ft (2.13 m) Total Height**  
T: 5  
M: 2

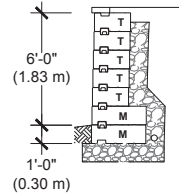

**8 ft (2.44 m) Total Height**  
T: 1  
M: 7

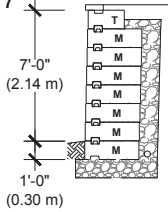

**9 ft (2.74 m) Total Height**  
T: 1  
M: 7  
B: 1

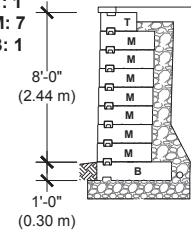

**10 ft (3.05 m) Total Height**  
M: 7  
B: 3

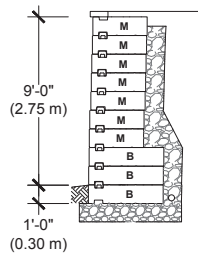

**11 ft (3.35 m) Total Height**  
M: 3  
B: 8

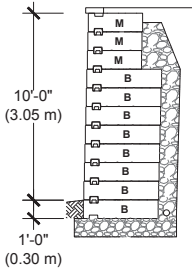

**12 ft (3.66 m) Total Height**  
M: 3  
B: 8  
BE: 1

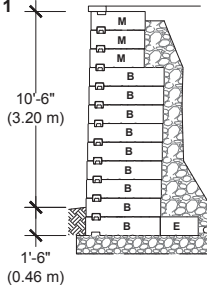

**13 ft (3.96 m) Total Height**  
M: 3  
B: 8  
BE: 2

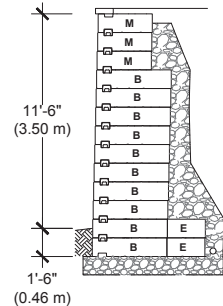

VISIT [WWW.TECHO-BLOC.COM](http://WWW.TECHO-BLOC.COM) FOR COMPLETE DESIGN CHART DOCUMENT  
(USA AND CANADA VERSIONS)

**14 ft (4.27 m) Total Height**  
M: 3  
B: 8  
BE: 3

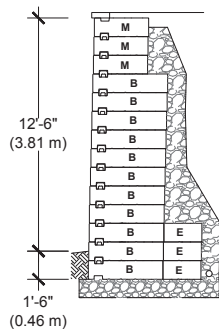

**15 ft (4.57 m) Total**  
B: 12  
BE: 3

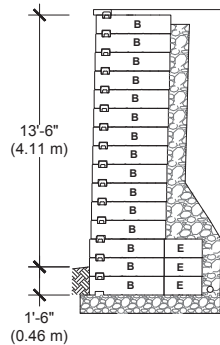

**16 ft (4.88 m) Total Height**  
B: 9  
BE: 7

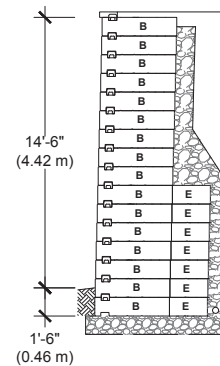

**17 ft (5.18 m) Total Height**  
B: 5  
BE: 12

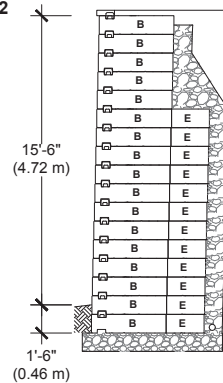

- The information contained in the design charts is supplied for information purposes only and as such should only be used for preliminary designs.
- The height (H) of the wall does not include the thickness of the cap.
- Soil parameters: retained soil ( $\phi=34^\circ$ ,  $\gamma = 130$  pcf); foundation soil ( $\phi=34^\circ$ ,  $\gamma = 120$  pcf)
- A qualified engineer should be consulted for the final design to be used for construction.
- The foundation soil must be able to support the wall system. The bearing capacity of the foundation soil, settlement, and global stability must be verified and validated by a qualified geotechnical engineer.
- The seismic analysis is not included.
- The design charts do not apply to tiered walls.
- The charts assume that the walls are constructed in accordance with Techo-Bloc specifications, good construction practice and an adequate drainage system.
- Engineering judgement should be used when interpolating between heights.
- Techo-Bloc and its predecessors, successors, beneficiaries, employees, associates, administrators and insurers accepts no liability for the incorrect use of information contained in the design charts.
- For further information, please contact our technical service department.

#### LEGEND :

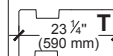

**TOP UNIT**

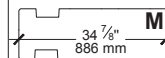

**MIDDLE UNIT**

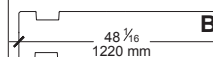

**BASE UNIT**

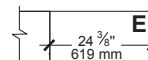

**EXTENDER UNIT**

# INSTALLATION GUIDE

## CAVITY INFILL - SKYSCRAPER

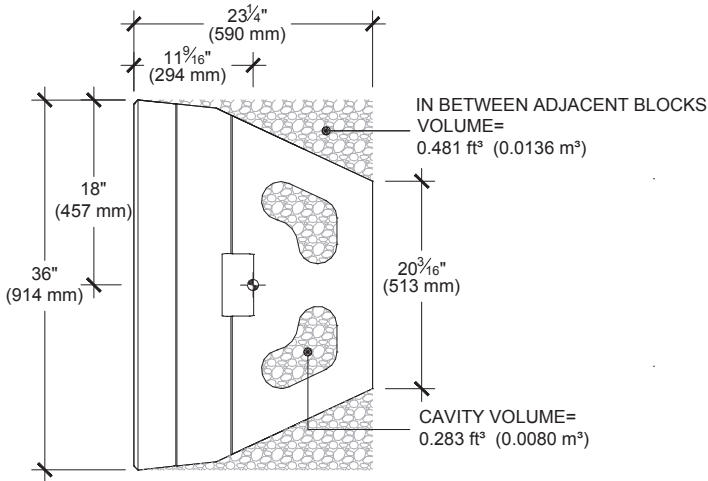

### SKYSCRAPER TOP

AGGREGATE INFILL QUANTITY	PER UNIT	±1.53 ft³	(±0.043 m³)
		±147.91 lb	(±66.65 kg)
PER WALL AREA		±0.51 ft²/ft²	(±0.16 m³/m²)
		±49.37 lb/ft²	(±248 kg/m²)

\*Assumed aggregate unit weight of 96.8 lb/ft³ (1550 kg/m³)

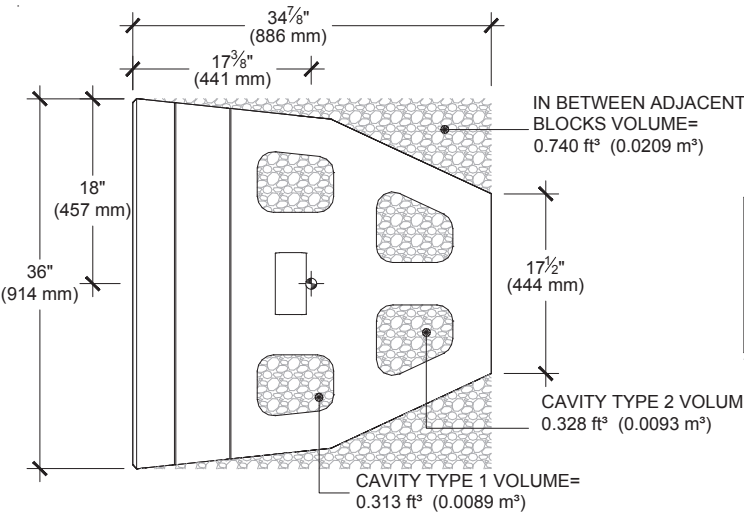

### SKYSCRAPER MIDDLE

AGGREGATE INFILL QUANTITY	PER UNIT	±2.76 ft³	(±0.078 m³)
		±267.17 lb	(±120.9 kg)
PER WALL AREA		±0.92 ft²/ft²	(±0.28 m³/m²)
		±89.06 lb/ft²	(±434 kg/m²)

\*Assumed aggregate unit weight of 96.8 lb/ft³ (1550 kg/m³)

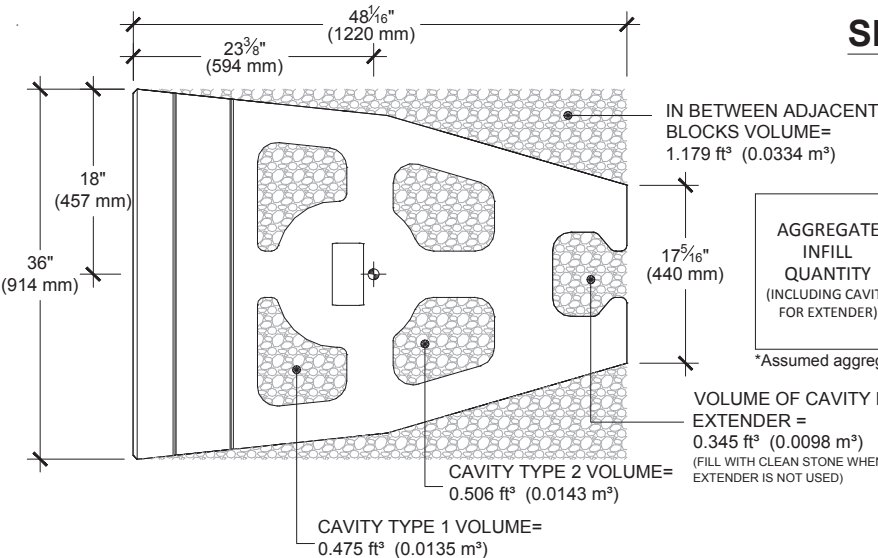

### SKYSCRAPER BASE

AGGREGATE INFILL QUANTITY (INCLUDING CAVITY FOR EXTENDER)	PER UNIT	±4.67 ft³	(±0.132 m³)
		±452.06 lb	(±204.6 kg)
PER WALL AREA		±1.56 ft²/ft²	(±0.47 m³/m²)
		±151.01 lb/ft²	(±728.5 kg/m²)

\*Assumed aggregate unit weight of 96.8 lb/ft³ (1550 kg/m³)

# INSTALLATION GUIDE

## CAVITY INFILL - SKYSCRAPER

### SKYSCRAPER BASE + EXTENDER(S)

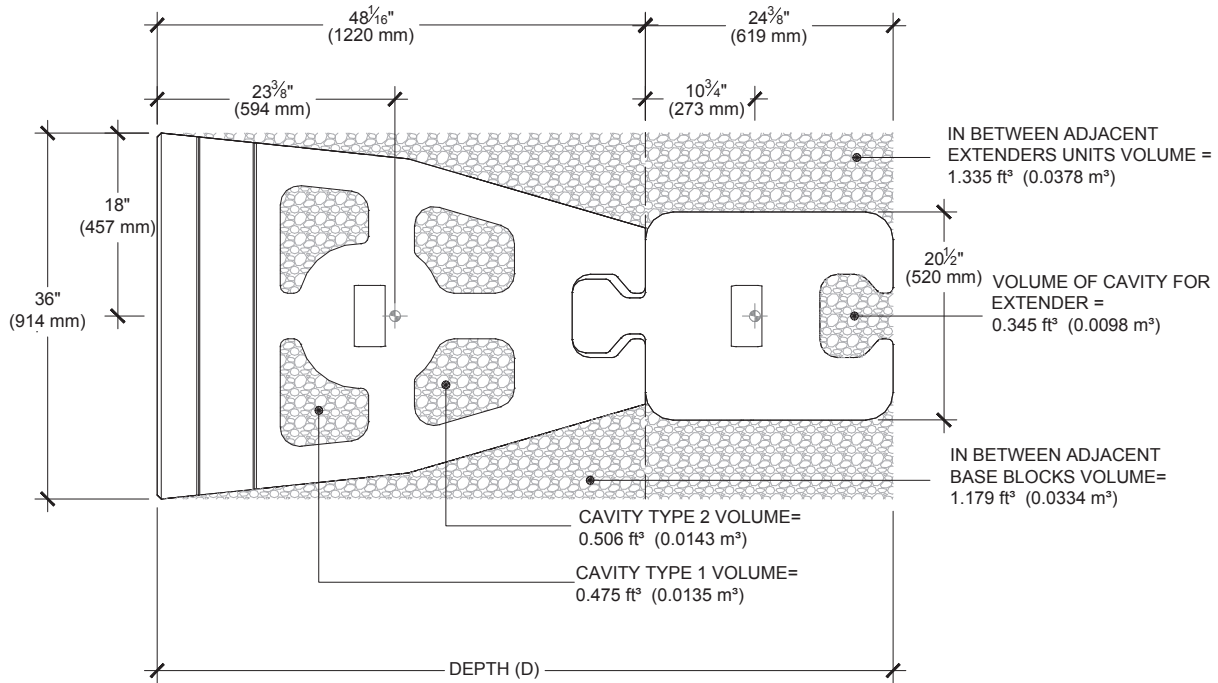

#### Aggregate Infill Quantity (INCLUDING CAVITY FOR EXTENDER)

# OF EXTENDERS	DEPTH (D)		PER UNIT			PER WALL AREA				
	INCHES	MM	ft³	m³	lb	kg	ft²/ft²	m²/m²	lb/ft²	kg/m²
1	72 3/8 "	1839 mm	±7.35 ft³	(±0.208 m³)	±711 lb	(±322 kg)	±2.45 ft²/ft²	(± 0.75 m²/m²)	±237 lb/ft²	(±1163 kg/m²)
2	96 3/4 "	2458 mm	±10.02 ft³	(±0.283 m³)	±970 lb	(±439 kg)	±3.34 ft²/ft²	(± 1.02 m²/m²)	±323 lb/ft²	(±1581 kg/m²)
3	121 1/8 "	3077 mm	±12.69 ft³	(±0.359 m³)	±1228 lb	(±556 kg)	±4.23 ft²/ft²	(± 1.29 m²/m²)	±409 lb/ft²	(±2000 kg/m²)
4	145 1/2 "	3696 mm	±15.36 ft³	(±0.435 m³)	±1487 lb	(±674 kg)	±5.12 ft²/ft²	(± 1.56 m²/m²)	±496 lb/ft²	(±2418 kg/m²)
5	169 7/8 "	4315 mm	±18.03 ft³	(±0.510 m³)	±1745 lb	(±791 kg)	±6.01 ft²/ft²	(± 1.83 m²/m²)	±582 lb/ft²	(±2837 kg/m²)
6	194 1/4 "	4934 mm	±20.70 ft³	(±0.586 m³)	±2004 lb	(±908 kg)	±6.9 ft²/ft²	(± 2.1 m²/m²)	±668 lb/ft²	(±3255 kg/m²)

\*Assumed aggregate unit weight of 96.8 lb/ft³ (1550 kg/m³)

# INSTALLATION GUIDE

## GRAVITY WALLS - SKYSCRAPER

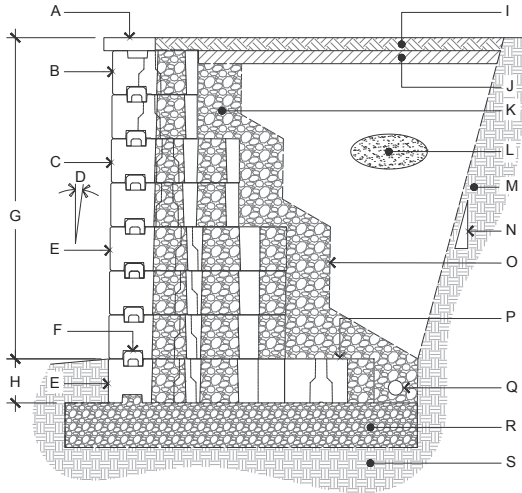

**GRAVITY NEAR VERTICAL WALL DETAIL**

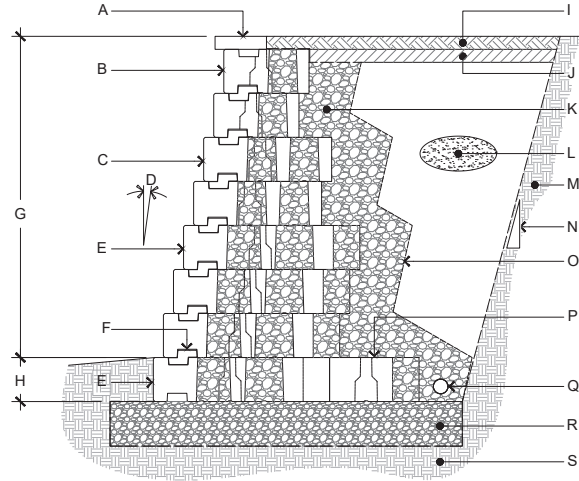

**GRAVITY NEAR INCLINED WALL DETAIL**

**A.** CAP FROM TECHO-BLOC

**B.** SKYSCRAPER TOP UNIT FROM TECHO-BLOC

**C.** SKYSCRAPER MIDDLE UNIT FROM TECHO-BLOC

**D.** WALL INCLINATION: 0.8° (NEAR VERTICAL)  
12.7° (INCLINED)

**E.** SKYSCRAPER BASE UNIT FROM TECHO-BLOC

**F.** PRECAST CONCRETE "U" CONNECTOR

**G.** EXPOSED HEIGHT

**H.** EMBEDMENT DEPTH

**I.** TOP SOIL

**J.** LOW PERMEABILITY SOIL

**K.** ¾" (20 mm) CLEAN STONE, 12" (300 mm) THICK MIN

**L.** COMPACTED BACKFILL

**M.** RETAINED SOIL

**N.** EXCAVATION ACCORDING TO LOCAL SAFETY  
REGULATIONS

**O.** GEOTEXTILE

**P.** SKYSCRAPER EXTENDER UNIT FROM TECHO-BLOC

**Q.** PERFORATED DRAIN

**R.** LEVELING PAD

**S.** FOUNDATION SOIL



(Available Spring 2026) **SYSTEMA**

**DESCRIPTION:** Wall **TEXTURE:** Smooth

**Pallet Overview**

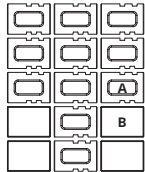

Smooth Chestnut Brown  
Smooth Caffè Crema  
Smooth Beige Cream  
Smooth Greyed Nickel  
Smooth Shale Grey  
Smooth Onyx Black

**Specifications per pallet**



A - 22 units / pallet



B - 8 units / pallet

	Imperial	Metric
Dimension Front (L x D x H) <b>A</b>	14 x 10 x 7 1/16	356 x 254 x 180
Dimension Back (L x D x H) <b>A</b>	14 x 10 x 7 1/16	356 x 254 x 180
Dimension Front (L x D x H) <b>B</b>	14 x 10 x 7 1/16	356 x 254 x 180
Dimension Back (L x D x H) <b>B</b>	14 x 10 x 7 1/16	356 x 254 x 180
Cubing	30 units	30 units
	20.69 ft <sup>2</sup>	1.92 m <sup>2</sup>
Approx. Weight	1 918 lbs	870 kg
Number of rows	2	
Coverage per row	10.35 ft <sup>2</sup>	0.96 m <sup>2</sup>
Lin. coverage per row	17.5 lin. ft	5.34 lin. m

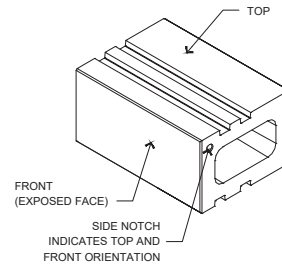

**NOTES**

See page 6 for icons description.

**COMPATIBLE CAPS**

See page 145 for product compatibility.

NOTE: PALLETIZED UPRIGHT

See page 146 to 161 for more technical information.

Systema walls are recommended for geogrid-reinforced applications up to 6 ft (1.8 m); taller reinforced walls (up to 10 ft [3.0 m]) may be feasible when designed by a qualified engineer based on site-specific conditions and project requirements.

# INSTALLATION GUIDE

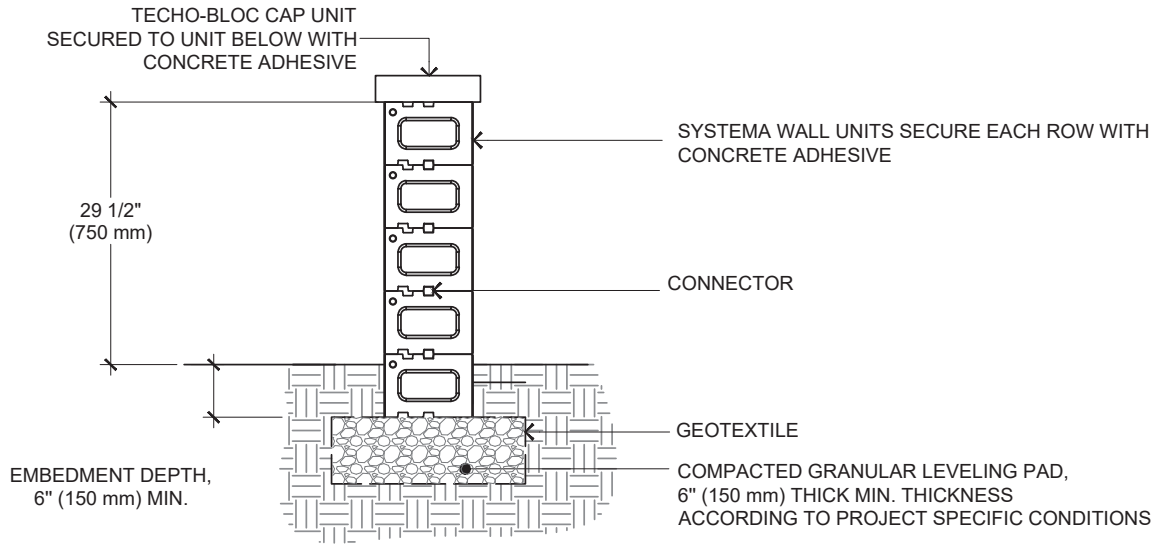

## FREESTANDING WALL

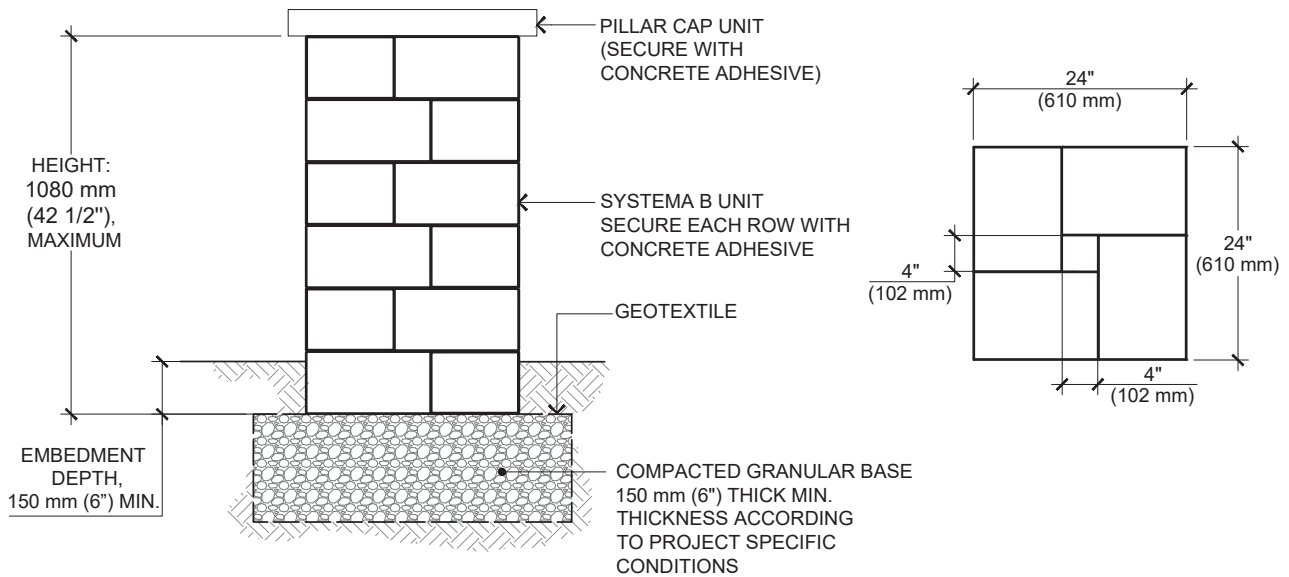

## PILLAR

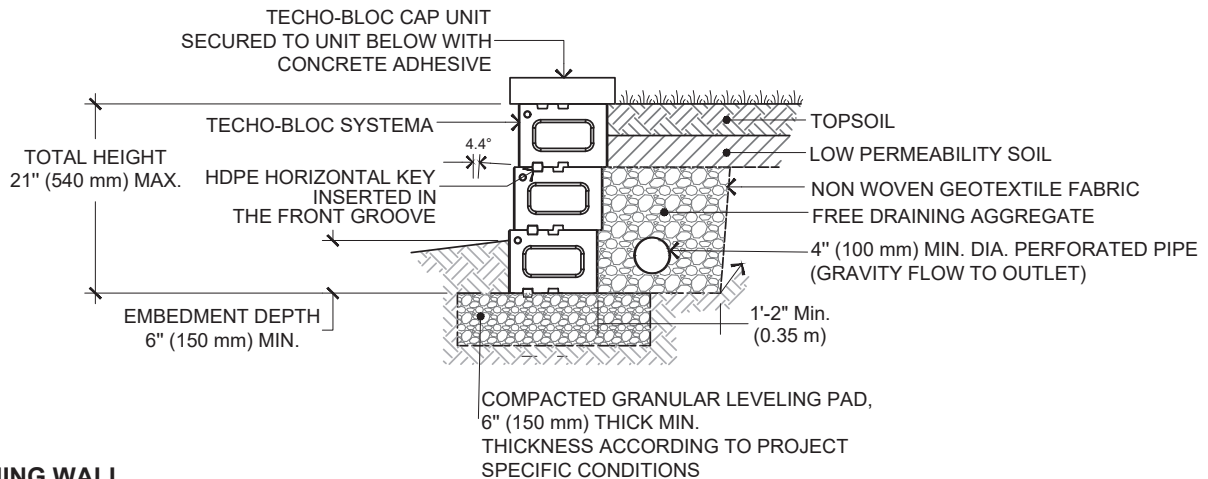

## RETAINING WALL



## TRAVERTINA RAW

**DESCRIPTION:** Double-sided wall **TEXTURE:** Brushed Travertine

### Pallet Overview

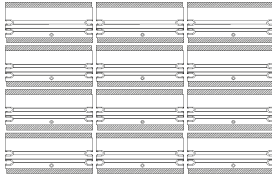

Brushed Travertine  
Rock Garden Brown

Brushed Travertine  
Ivory

Brushed Travertine  
Riviera

### Specifications per pallet



48 units / pallet

	Imperial	Metric
Product dimension (L x D x H)	15 7/8 x 7 15/16 x 6	403 x 202 x 152
Cubing	31.75 ft <sup>2</sup>	2.95 m <sup>2</sup>
	63.5 lin. ft	19.36 lin. m
Approx. Weight	2 902 lbs	1 316 kg
Number of rows	4	
Coverage per units	0.66 ft <sup>2</sup>	0.06 m <sup>2</sup>
Coverage per row	7.94 ft <sup>2</sup>	0.74 m <sup>2</sup>
Linear coverage per row	15.88 lin. ft	4.84 lin. m

### NOTES

See page 6 for icons description.

#### COMPATIBLE CAPS

See page 145 for product compatibility.

The dimensional tolerance for Stonedge wet cast retaining wall units is: + 3/16" (5 mm) for height and + 1/2" (13 mm) for length and width. During the installation, the level between adjacent wall units will vary (usually more than for a dry cast wall unit) in order to obtain a more realistic appearance of a natural stone wall.

See page 146 to 161 for more technical information.



# TRAVERTINA RAW

**DESCRIPTION:** Corner/Pillar **TEXTURE:** Brushed Travertine

Specifications per pallet	Imperial	Metric
Product dimension (L×D×H)	15 7/8 × 7 15/16 × 6	403 × 202 × 152
Cubing	24 units	24 units
Approx. Weight	1 576 lbs	715 kg
Number of rows	2	
Pillar height	36 in	914 mm



24 units / pallet

## Pallet Overview



Rock Garden Brown

Brushed Travertine



Ivory

Brushed Travertine



Riviera

Brushed Travertine



## NOTES

See page 6 for icons description.

See page 146 to 161 for more technical information.

### COMPATIBLE CAPS

See page 145 for product compatibility.

The dimensional tolerance for Stonedge wet cast retaining wall units is: + 3/16" (5 mm) for height and + 1/2" (13 mm) for length and width. During the installation, the level between adjacent wall units will vary (usually more than for a dry cast wall unit) in order to obtain a more realistic appearance of a natural stone wall.

# INSTALLATION GUIDE

## FREESTANDING WALLS - TRAVERTINA RAW

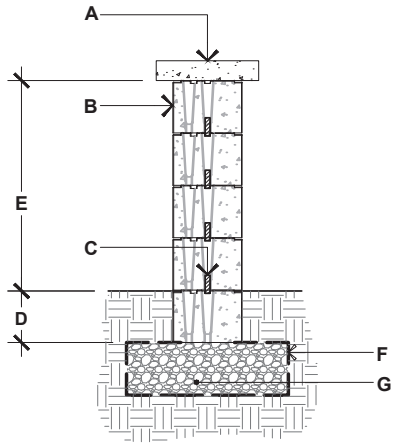

### TRAVERTINA RAW

- A. TECHO-BLOC CAP UNIT, SECURED TO UNIT BELOW WITH CONCRETE ADHESIVE
- B. TRAVERTINA RAW DOUBLE-SIDED WALL UNIT SECURE EACH ROW WITH CONCRETE ADHESIVE
- C. CONNECTOR
- D. EMBEDMENT DEPTH, 6" (150 mm) MIN.
- E. 24" (612 mm) MAX.
- F. GEOTEXTILE
- G. COMPACTED GRANULAR LEVELING PAD, 6" (150 mm) THICK MIN. THICKNESS ACCORDING TO PROJECT SPECIFIC CONDITIONS

## 90° CORNER OF A DOUBLE-SIDED WALL

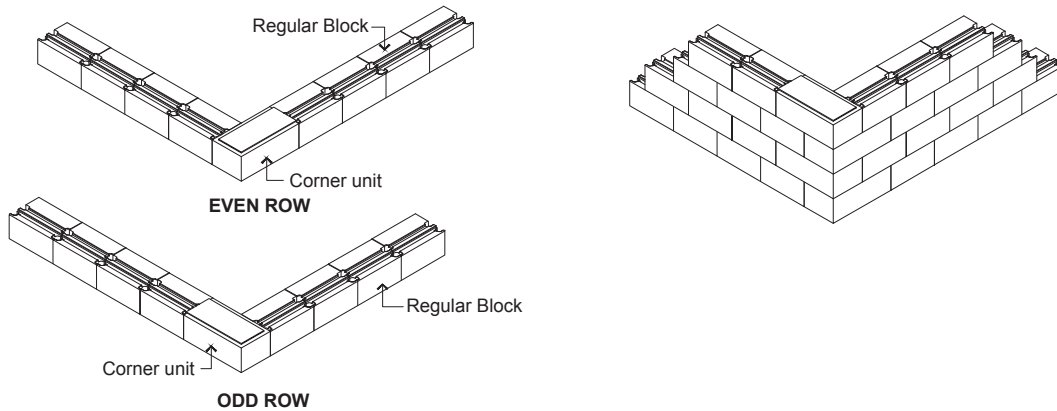

## DOUBLE-SIDED WALL - END OF A STRAIGHT WALL

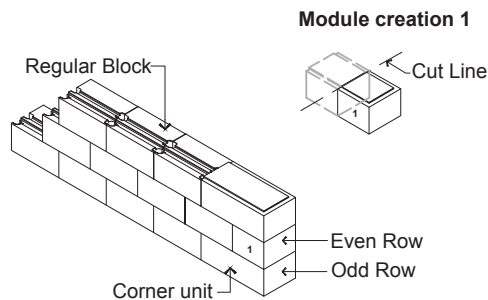

### GENERAL NOTES

1. Alternate odd and even rows.
2. Stagger joints from one row to the next.
3. Glue all modules at each row with Flexlock adhesive.

# INSTALLATION GUIDE

## PILLARS - TRAVERTINA RAW

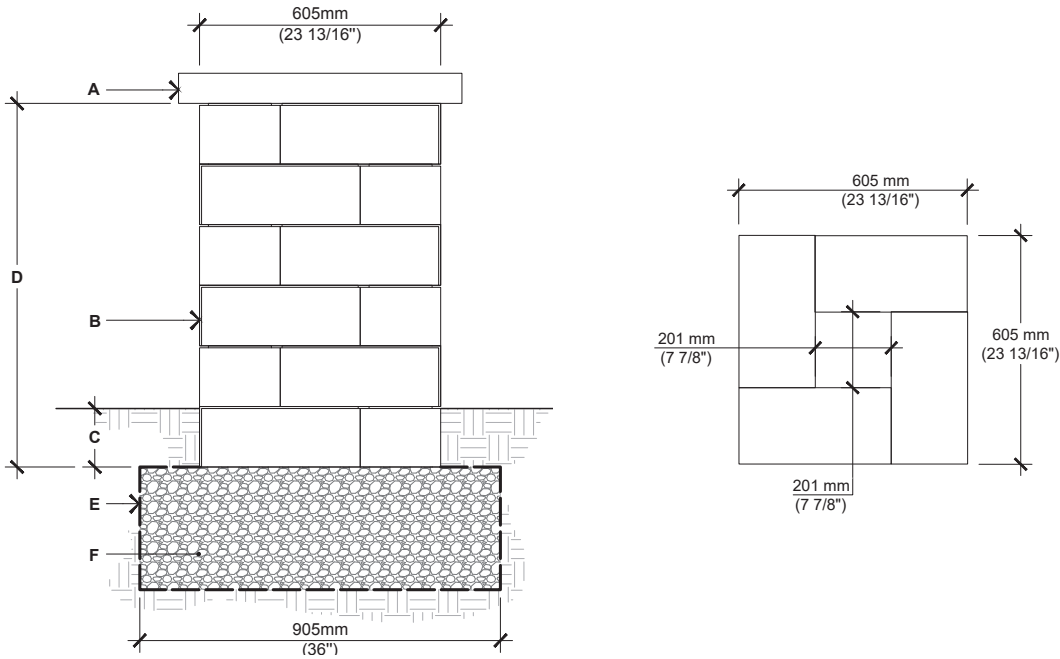

### TRAVERTINA RAW

- A. PILLAR CAP UNIT  
(SECURE WITH CONCRETE ADHESIVE)
- B. TRAVERTINA RAW PILLAR UNIT  
SECURE EACH ROW WITH CONCRETE ADHESIVE
- C. EMBEDMENT 6" (150 mm) MIN.
- D. 36" (917 mm), HEIGHT PER PALLET  
42" (1067 mm), MAXIMUM HEIGHT
- E. GEOTEXTILE
- F. COMPACTED GRANULAR BASE 6" (150mm)  
THICK MIN. THICKNESS ACCORDING TO  
PROJECT SPECIFIC CONDITIONS

For all possible combinations of pillars and caps, please refer to the correspondence table on page 145

### STEPS

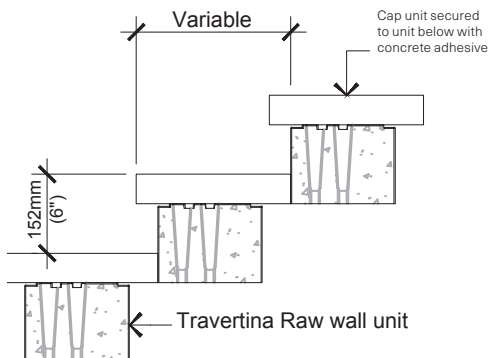

For all possible combinations of walls and caps, please refer to the correspondence table on page 145

Check with your local Building Codes to determine any restrictions or guidelines regarding the dimensions of steps (including riser height and step tread) as well as handrail specifications.