

HPC BURNERS FOR FIRE PITS

DESCRIPTION

Made for outdoor gas fire pits (natural or propane), the patented design of the Torpedo™ burner by HPC delivers the biggest CSA-certified flame on the market. Made of welded commercial-grade stainless steel, this burner seamlessly blends into any fire pit design.

WHAT COMES IN THE HPC BURNER BOX?

Valencia units: burner and connection valve, accessories, owners manual, spark igniter kit, vent covers, key valve bracket, 5 install collars and a cover, 65k orifice installed, 150k orifice loose.

Prescott units: burner and connection valve, accessories, owners manual, spark igniter kit, vent covers, key valve bracket, 4 install collars and a cover, 65k orifice installed, 150k orifice loose.

Brandon units: burner and connection valve, accessories, owners manual, spark igniter kit, vent covers, key valve bracket, 4 install collars and a cover, 65k orifice installed, 150k orifice loose.

Raffinato units: burner and connection valve, accessories, owners manual, spark igniter kit, vent covers, key valve bracket, 4 install collars and a cover 65k orifice installed, 150k orifice loose.

The burner and connection valve come as one part connected. Install collars go around the perimeter of the fire pit.

Lumi Bowl and Sculptura Collection: burner and connection valve, accessories, owners manual, key valve bracket, a vinyl cover, 65k orifice installed, 150k orifice loose.

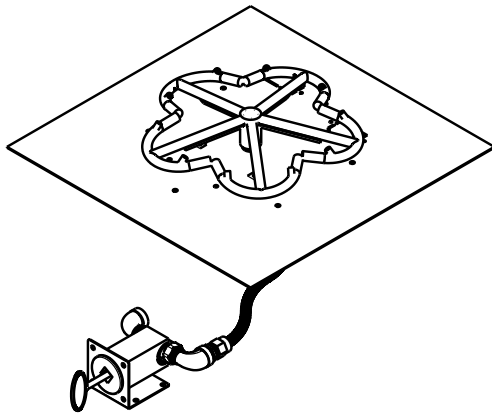

HPC SQUARE - Compatible with Brandon Square, Prescott and Sculptura Collection

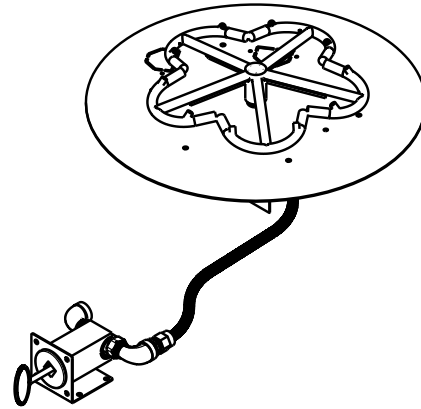

HPC ROUND - Compatible with Lumi, Sculptura Collection and Valencia

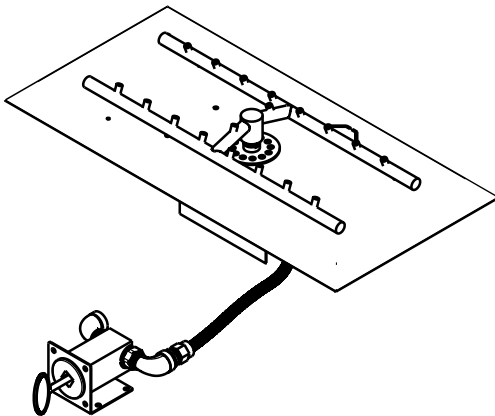

HPC RECTANGLE - Compatible with Brandon Rectangle, Raffinato and Sculptura Collection